

IGS-900 Tuner to IP Gateway



Datasheet and operation Manual

New Re-Designed in 2026: IGS-900 (Standard=SAT, Option: C=DVB-C/T...)

based on the IGS-924 V3 Version but with 16 tuner:



V 1.7

Table of Content

TABLE OF CONTENT.....	2
INTRODUCTION:	3
FEATURES	3
SPECIFICATIONS (DVB-T/T2/C UPON REQUEST – SEE ALSO END OF THIS DOCUMENT= UPDATE2026).....	4
SAFETY AND OTHER RECOMMENDATIONS:.....	5
IMPORTANT NOTES!.....	5
QUICK-START INSTALLATION:.....	8
NETWORK SETUP:	16
CHANGING THE USER-ACCOUNT:	17
DVB-C / T TUNING	17
TUNER-SETUP SAT:	18
ASI-INPUT(S):.....	24
SPTS OUTPUT SETTINGS: (ALSO SEE THE NOTE ABOVE).....	24
STREAM OUTPUT SETTINGS:	26
ADDON: BISS DECRYPTION:.....	27
CHECK THE STREAMS:	28
SOFTWARE UPDATES:.....	31
ANNEX-IGS-900C:.....	35
ANNEX MPEG	37
MPEG PSI/SI Information's:	37
RECOMMENDATIONS:	38
INSTALLATION GUIDE FOR F-CONNECTORS:	43
APPENDIX A.....	44
INSTALLATION AND SAFETY INSTRUCTIONS / MONTAGE UND SICHERHEITSHINWEISE	45
Umrechnungstabelle dBµV <-> dBm / <i>Conversions of Power @ 75Ω</i>	47
CONTACT:	50
Document History:	50
CE DECLARATION	51
DVB-C CHANNEL PLAN	52

Introduction:

The BLANKOM IGS-900 is a high performance and cost-effective SPTS / MPTS IP streamer.

Equipped with 16 DVB-S/S2x FTA (Free to Air unencrypted) tuner inputs, with BISS de-scrambling capabilities, up to 512 SPTS Stream channels through Gigabit Ethernet ports (parallel operation as redundant stream-I/O). Depending on the installed firmware the device can operate in SPTS (IPTV) Mode or 16x pass through MPTS-Mode (DVB over IP) by selecting it (device need to reboot if changing). To meet customers' various requirements, this device is also equipped with 2 ASI input ports which selected services can be streamed to the Gbe output.

The BLANKOM IGS-900 is also characterized with a high integration level, high performance and very cost effective. This streamer is very adaptable to new generations of IPTV headend systems i.e., in hospitality environments serving FreeToAir (FTA) content and BISS encrypted Services.

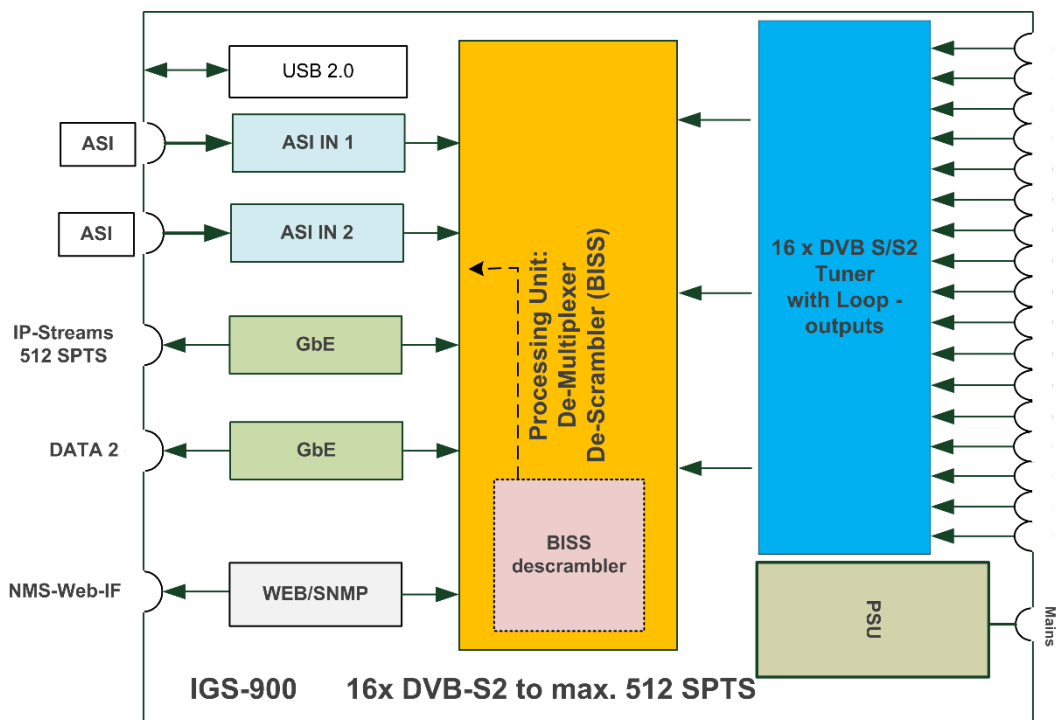

Features

- 16 modern Tuner inputs DVB-S/S2/S2x (DVB-C and DVB-T/T2 and ISDB-Tb optional)
- Supporting DiSEqC commands for up to 8 Satellite positions
- 2 ASI inputs
- IP (512 SPTS or 16 MPTS) over UDP, RTP / RTSP output
- BISS Service de-scrambling
- 2 Gigabit Ethernet (GE) mirrored output, up to 850 Mbps (SPTS)
- 2 independent GE output port, GE1 + GE2 (MPTS), SPTS can copy the Streams to different addresses
- Accurate PCR adjusting (SPTS)
- PID filtering and re-mapping (SPTS)
- PSI/SI rebuilding and editing (MPTS)
- "Null PKT Filter" function (MPTS)
- Webserver for inbuilt NetworkManagementSystem (NMS)
- Updates via WEB-IF

Depending on the region to be delivered, the power cords can be different like EURO or UK versions.

Specifications (DVB-T/T2/C upon request – see also end of this document= update2026)

Input	Optional 1: 16 DVB-S/S2x tuners input +2 ASI input---SPTS output	
	Optional 2: 14 DVB-S/S2x tuners input +2 ASI input --- MPTS output	
Tuner Section (DVB-S/S2/S2x)	Input Frequency	950-2150MHz
	Max Symbol rate	QPSK/8PSK /16APSK :0.5...45 MSps 8APSK: 0.5...40MSps 32APSK: 0.5...34MSps
	FEC/Code rate	QPSK: 1/2, 3/5, 2/3, 3/4, 4/5, 5/6, 8/9, 9/10, 13/45, 9/20, 11/20 8PSK: 3/5, 2/3, 3/4, 5/6, 8/9, 9/10 8APSK: 5/9-L, 26/45-L 16APSK: 2/3, 3/4, 4/5, 5/6, 8/9, 9/10, 1/2-L, 8/15-L, 5/9-L, 26/45, 3/5, 3/5-L, 28/45, 23/36, 2/3-L, 25/36, 13/18, 7/9, 77/90 32APSK: 3/4, 4/5, 5/6, 8/9, 9/10, 2/3-L, 32/45, 11/15, 7/9
	Constellation	QPSK, 8PSK, 8APSK, 16APSK, 32 APSK
Output	512 SPTS IP mirrored output over UDP and RTP/RTSP protocol through GE1 and GE2 port, Unicast and Multicast	
	16 MPTS IP output (for Tuner passthrough) over UDP and RTP/RTSP protocol through GE1 and GE2 port, Unicast and Multicast	
BISS de-scrambling	Mode 1, Mode E (Up to 850Mbps) (de-scrambling selected service)	
Miscellaneous	Dimension(W×L×H)	482mm×410mm×44mm
	Approx. weight	3.6kg
	Environment	0...45°C(work); -20...80°C (Storage)
	Power requirements	100...240VAC, 50/60Hz
	Power consumption	20W

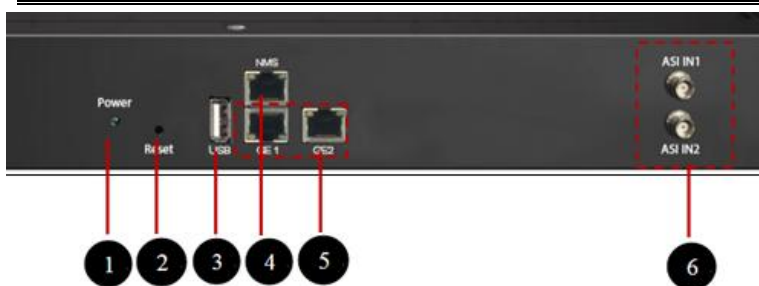

Depending on Model and old/new HW types. IGS-924/900 V3/4 or A-types have now a different Front panel and Power switch at the front.

1	Power indicator
2	Reset: Reset webmaster IP address, recover it to default IP address
3	USB port for upgrade
4	NMS port: Network management interface
5	Data port (GE1&GE2) : IP out port
6	ASI input port

Safety and other recommendations:

Assure climatic environment rules for electronic machines like this, Grounding rules as well. Installation should be done by a certified electrician.

⚠ Caution:

Before connecting power cord to Tuner to IP Gateway, you should set the power switch to "OFF". Do not connect the RF-cable (F-plugs) when the unit is running.

Important Notes!

This manual is for use by qualified personnel only. Handling this device or system requires special electronic technical knowledge. To reduce the risk of electrical shock or damage to the equipment, do not perform any servicing other than the installation and operating instructions contained in this manual unless you are qualified to do so. This device operates in the given voltage and frequency range without requiring manual adjustment.

Do not open the top case w/o unplugged power source because serious injury or death may be the result! Inside are components under risk from electrostatic discharge. To avoid equipment damages do not touch these components or, observe the respective handling rules!

For continued protection against fire, the fuses may only be replaced by identical fuses with the same electrical specifications which are designed for the corresponding fuse positions.

No part of this publication may be reproduced in any form or by any means or used to make any derivative work (such as translation, transformation or adaptation) without the written permission from Blankom / IRENIS GmbH.

IRENIS GmbH reserves the right to revise this publication and make changes in its content from time to time, whereby it shall not be obligatory for IRENIS GmbH to provide notification of such revision or change.

IRENIS GmbH provides this manual without warranty of any kind, neither implied nor expressed, this includes also any warranties regarding the merchantability and fitness for a particular purpose. IRENIS GmbH may improve this manual or make changes in the products described herein at any point of time.

This Product is manufactured in PRC (China), HS-Code: 85176200

Anmerkung:



Alle von uns veröffentlichten Betriebsanleitungen richten sich an den Antennen- und IT-Fachmann, der über grundlegende Kenntnisse der Empfangs-, Netzwerk- und Anlagentechnik verfügt. Die Einhaltung aller relevanten Vorschriften und Richtlinien für den Aufbau und Betrieb von solchen Anlagen obliegt dem Installateur und/oder dem Betreiber. Insbesondere sind die in den jeweiligen Ländern geltenden Vorschriften und Richtlinien für die Inbetriebnahme speziell für den Stromanschluß und alle mit den Produkten in Zusammenhang stehenden und geltenden Normen und Gesetze einzuhalten.

Remark:



All operating instructions published by us are intended for the antenna and IT specialist who has basic knowledge of reception, network and system technology. Compliance with all relevant regulations and

guidelines for the installation and operation of such systems is the responsibility of the installer and/or the operator. In particular, the regulations and guidelines applicable in the respective countries for commissioning, especially for the power connection, and all standards and laws related to the products must be complied with.

Annotation :

Tous les modes d'emploi que nous publions sont destinés aux professionnels de l'antenne et de l'informatique qui ont des connaissances de base en matière de réception, de mise en réseau et de technologie des équipements. Le respect de toutes les réglementations et directives pertinentes pour l'installation et l'exploitation de ces systèmes relève de la responsabilité de l'installateur et/ou de l'exploitant. En particulier, il convient de respecter les réglementations et directives applicables dans les pays respectifs pour la mise en service, notamment pour le raccordement électrique, ainsi que toutes les normes et lois relatives aux produits.

Annotazione:

Tutte le istruzioni per l'uso da noi pubblicate sono destinate al professionista dell'antenna e dell'informatica che ha una conoscenza di base della tecnologia di ricezione, di rete e delle apparecchiature. Il rispetto di tutti i regolamenti e le linee guida pertinenti per l'installazione e il funzionamento di tali sistemi è responsabilità dell'installatore e/o dell'operatore. In particolare, devono essere rispettati i regolamenti e le linee guida applicabili nei rispettivi paesi per la messa in funzione, soprattutto per il collegamento alla rete elettrica e tutte le norme e le leggi relative ai prodotti.

Anotación:

Todas las instrucciones de uso publicadas por nosotros se dirigen al profesional de la antena y de la informática que tiene conocimientos básicos de recepción, de redes y de tecnología de equipos. El cumplimiento de todos los reglamentos y directrices pertinentes para la instalación y el funcionamiento de dichos sistemas es responsabilidad del instalador y/o del operador. En particular, deben cumplirse los reglamentos y directrices aplicables en los respectivos países para la puesta en marcha, especialmente para la conexión de la energía y todas las normas y leyes relacionadas con los productos.

Anotação:

Todas as instruções de operação publicadas por nós são destinadas ao profissional de antena e TI que possui conhecimentos básicos de recepção, rede e tecnologia de equipamentos. O cumprimento de todos os regulamentos e diretrizes relevantes para a instalação e operação de tais sistemas é de responsabilidade do instalador e/ou do operador. Em particular, os regulamentos e diretrizes aplicáveis nos respectivos países para comissionamento, especialmente para a conexão de energia e todas as normas e leis relacionadas aos produtos devem ser obedecidas.

Installation Notes

All types of the IRENIS-BLANKOM family are 19" devices with 1 RU height designed for installation in 19" racks. In addition to the front panel screws, an internal module support is required at the rack. Depending on the Frontend used and the operating adjustments, the RF-input port carries DC Voltage (13V /18V, max. 400 mA).

By connecting a mains cable, the device can become functional without any auxiliary appliances. The power supply units are almost (! Please check rear) designed for the wide range of 100-230V AC , 50/60Hz; a manual adjustment of the voltage is not necessary.

For some models, the second power connector is feeding another independent power supply for internal redundancy. For a maximum of redundancy, both power supplies should use different circuits.

All the outputs are decoupled from one another. Thus, the circuit does not have any effect on the functioning of the device. Connections that are not required need not to be terminated.

Suggestion: CAT 6E Ethernet cable for Gigabit-Ethernet

Note:

IPv4 global scope sessions use multicast addresses in the range 224.2.128.0 - 224.2.255.255 with SAP Announcements being sent to 224.2.127.254 Port 9875 (note that 224.2.127.255 is used by the obsolete SAPv0 and MUST NOT be used).

IPv4 administrative scope sessions using administratively scoped IP multicast. The multicast address to be used for announcements is the highest multicast address in the relevant administrative scope zone.

For example, if the scope range is 239.16.32.0 - 239.16.33.255, then 239.16.33.255 is used for SAP Announcements.

Quick-Start Installation:

The user can control and set the configuration of the device with any computer by connecting to the web server-Interface (WebIF) by the 100BaseT NMS Port. The user should ensure that the computer's IP address is different from other device's IP address; otherwise, it might cause an IP conflict. Be sure to set it in the same network range.

Default Login-Data is 192.168.0.136 (default factory address) are **admin/admin** NEW2026: **admin/m89xC2F7** and a captcha:



Note: We recommend using always the newest version of the browser Firefox or CHROME.

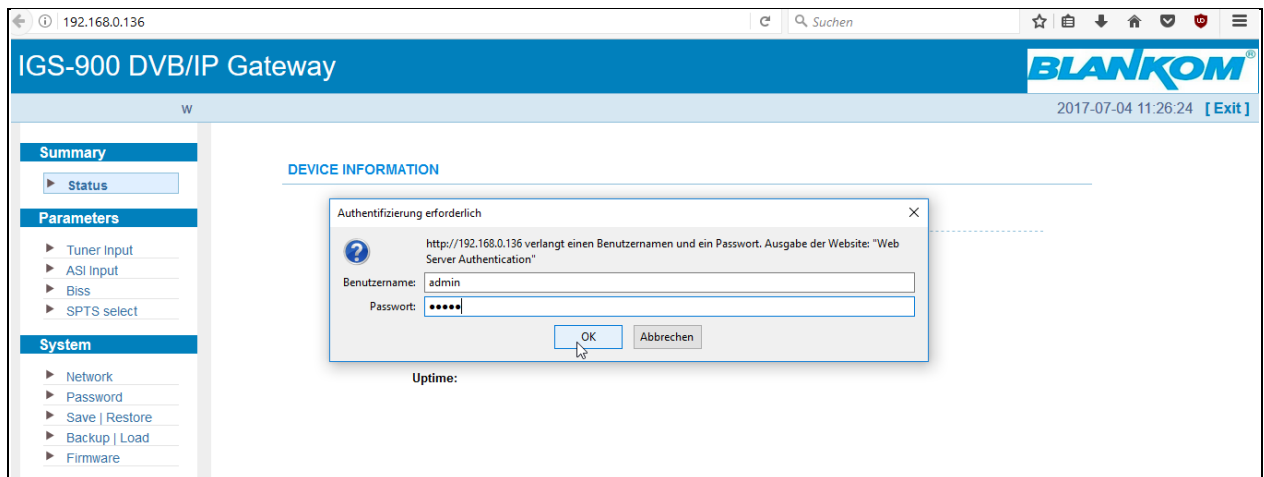

Which lets you start in the STATUS display:

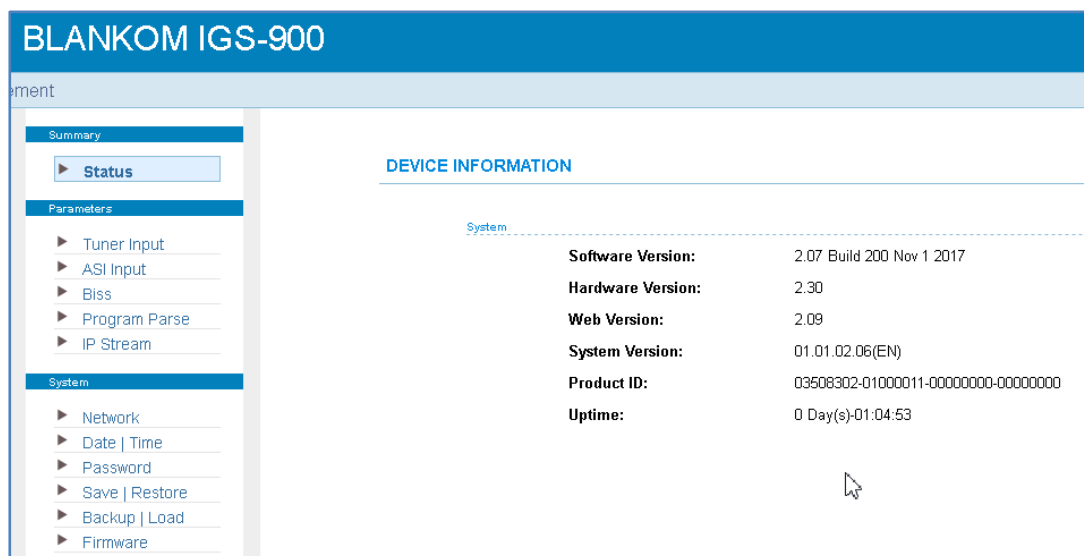

Menu is different in MPTS (see above)

Please select the operating mode for SPTS (default) or MPTS in the Firmware section:

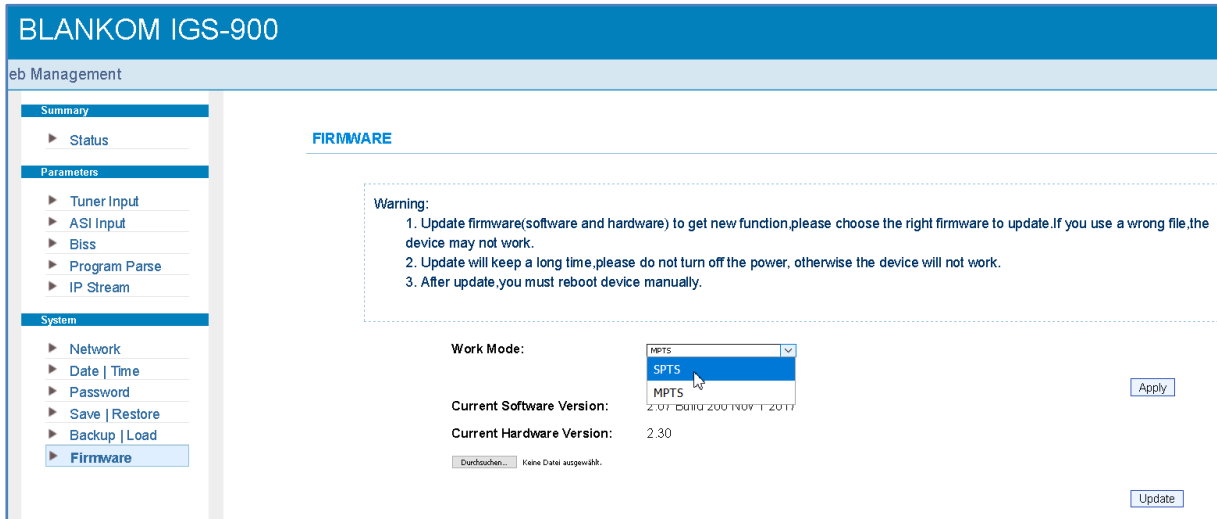

It might be named "Bypass" (=MPTS) or SPTS mode (dep. on model)

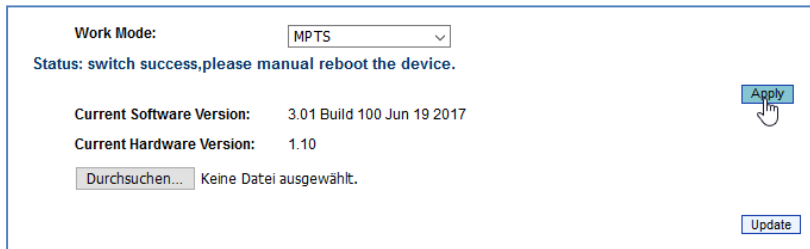

**Manually reboot and maybe better to save the config first?
Internally and external:**

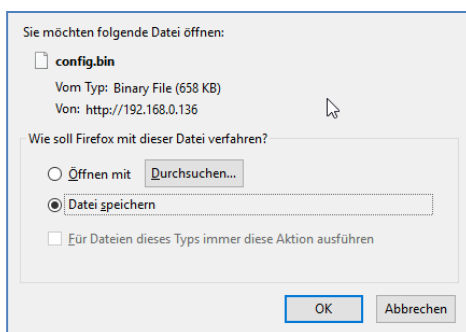
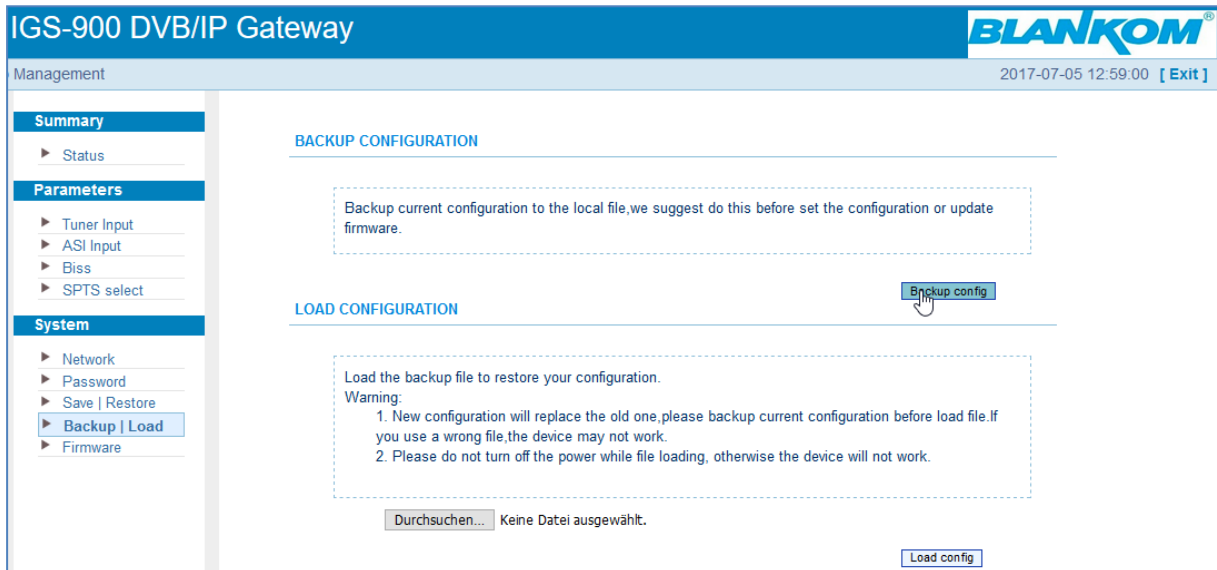

The file can be uploaded by LOAD CONFIGURATION.

The Safe-Restore menu is self-explaining: It internally SAVES or RESTORE the settings.

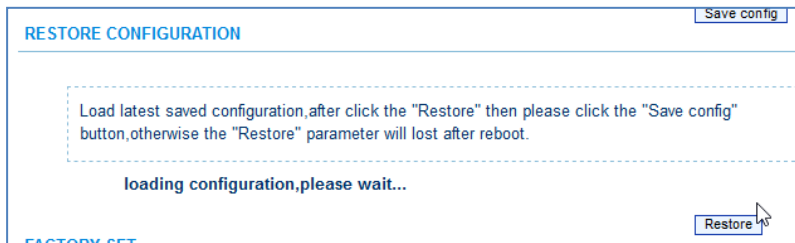
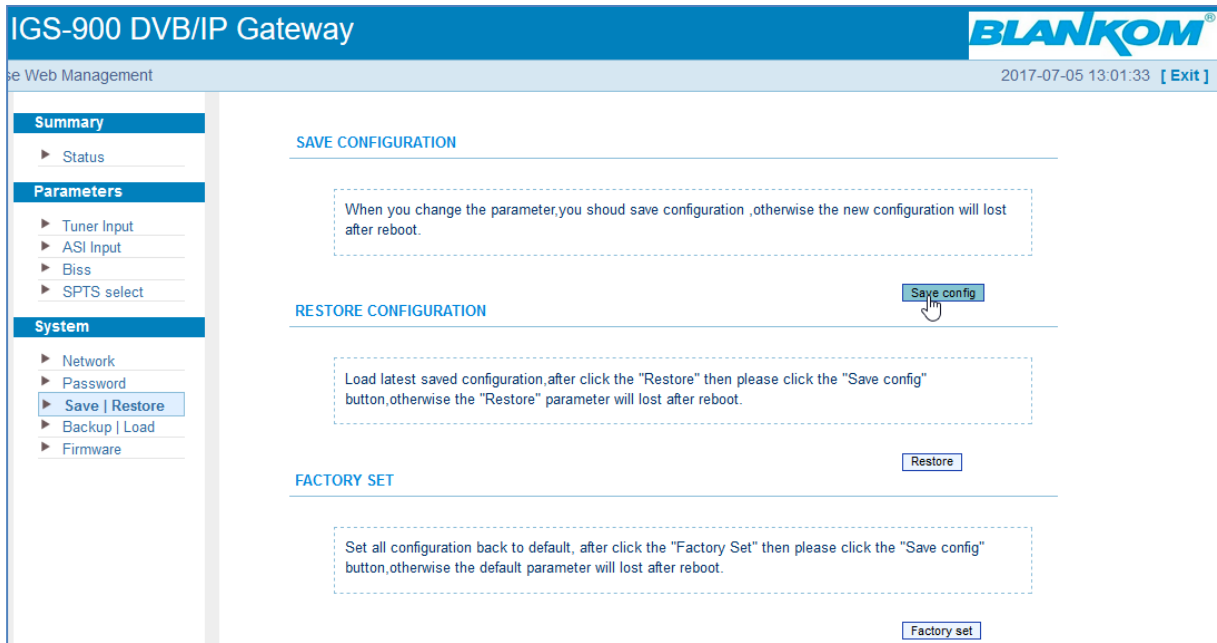

Load an external previously saved config is almost better:

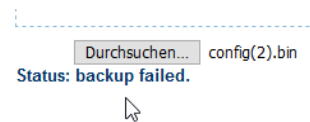
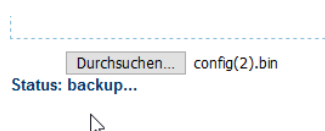
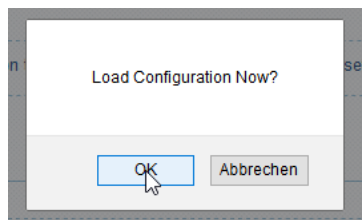
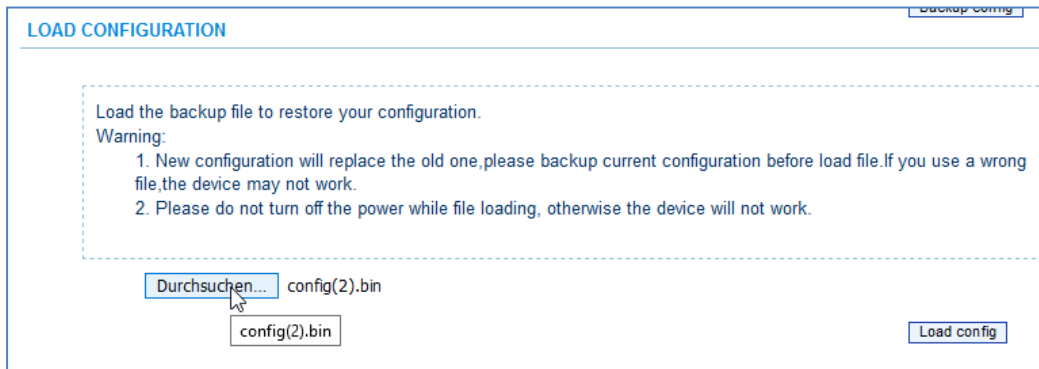

Try and error ;-) Reason: We have changed the SPTS mode to MPTS operation and that doesn't accept the previous saved settings from the SPTS mode. So, we go back to SPTS.

Just to show the difference for MPTS – outputs – only 16 IP streams can be assigned. You should decide whether a stream goes through GbE 1 or 2 so please balance the MPTS streams if more than 800 Mb/s are streamed in total.

MPTS Bypass mode = SAT Transponder -> DVB-C: 16 IP-MPTS out streams can be assigned:

IGS-900 DVB/IP Gateway

Web Management

IP STREAM

Summary

- Status

Parameters

- Tuner Input
- ASI Input
- Biss
- Program Parse
- IP Stream**

System

- Network
- Date | Time
- Password
- Save | Restore
- Backup | Load
- Firmware

Output Port: GE1

Output Protocol: UDP

IP Out

Enable	Null PKT Filter	Output IP	Port
<input checked="" type="checkbox"/>	<input type="checkbox"/>	224.2.2.2	2000
<input checked="" type="checkbox"/>	<input type="checkbox"/>	224.2.2.2	2002
<input checked="" type="checkbox"/>	<input type="checkbox"/>	224.2.2.2	2004
<input checked="" type="checkbox"/>	<input type="checkbox"/>	224.2.2.2	2006
<input checked="" type="checkbox"/>	<input type="checkbox"/>	224.2.2.2	2008
<input checked="" type="checkbox"/>	<input type="checkbox"/>	224.2.2.2	2010
<input checked="" type="checkbox"/>	<input type="checkbox"/>	224.2.2.2	2012
<input checked="" type="checkbox"/>	<input type="checkbox"/>	224.2.2.2	2014
<input checked="" type="checkbox"/>	<input type="checkbox"/>	224.2.2.2	2016
<input checked="" type="checkbox"/>	<input type="checkbox"/>	224.2.2.2	2018
<input checked="" type="checkbox"/>	<input type="checkbox"/>	224.2.2.2	2020
<input checked="" type="checkbox"/>	<input type="checkbox"/>	224.2.2.2	2022
<input checked="" type="checkbox"/>	<input type="checkbox"/>	224.2.2.2	2024
<input checked="" type="checkbox"/>	<input type="checkbox"/>	224.2.2.2	2026
<input checked="" type="checkbox"/>	<input type="checkbox"/>	224.2.2.2	2028
<input checked="" type="checkbox"/>	<input type="checkbox"/>	224.2.2.2	2030

Default Apply

Note: Depending on installed Firmware, the Stream output selection may be different:

BLANKOM®

PROGRAM SELECT

Summary

- Status

Parameters

- Tuner Input
- ASI Input
- TS Config
- Biss
- SPTS select**

System

- Network
- Password
- Save | Restore
- Backup | Load
- Firmware

CA Filter

PidRemap

Refresh Input

Refresh Output

All Input

All Output

Parse program time out: 60 seconds

Instead of IP stream there will be SPTS select. By click on the service name a popup opens.

Differences to IGS-900A/924A Versions: Login https with captcha, No MPTS (Bypass)-Mode:

IGS-900A

Warning to restore the output.

BLANKOM®

Firmware

Warning:

1. Upgrade firmware(software and hardware) to get new function, please choose the right firmware to upgrade. If you use a wrong file, the device may not work.
2. Upgrade will keep a long time, please do not turn off the power, otherwise the device will not work.
3. After upgrade, you must reboot device manually.

Current Software Version: 01.00.05 Build 158.00 May 19 2026

Current Hardware Version: 01.01.02

File: Keine Datei ausgewählt.

Upgrade

The IGS-900A/924A are special SPTS only versions with a bigger FPGA and different Firmware supporting dynamic PMT and EIT demultiplexing to the SPTS streams.

An example of the new IGS-900C version design (not the A-version):

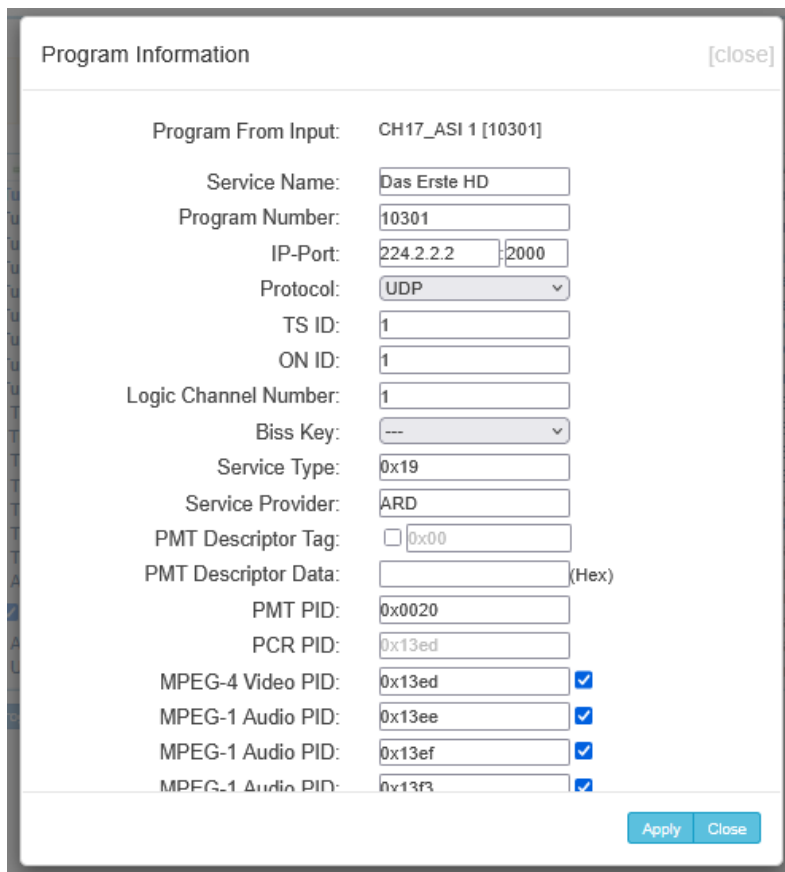
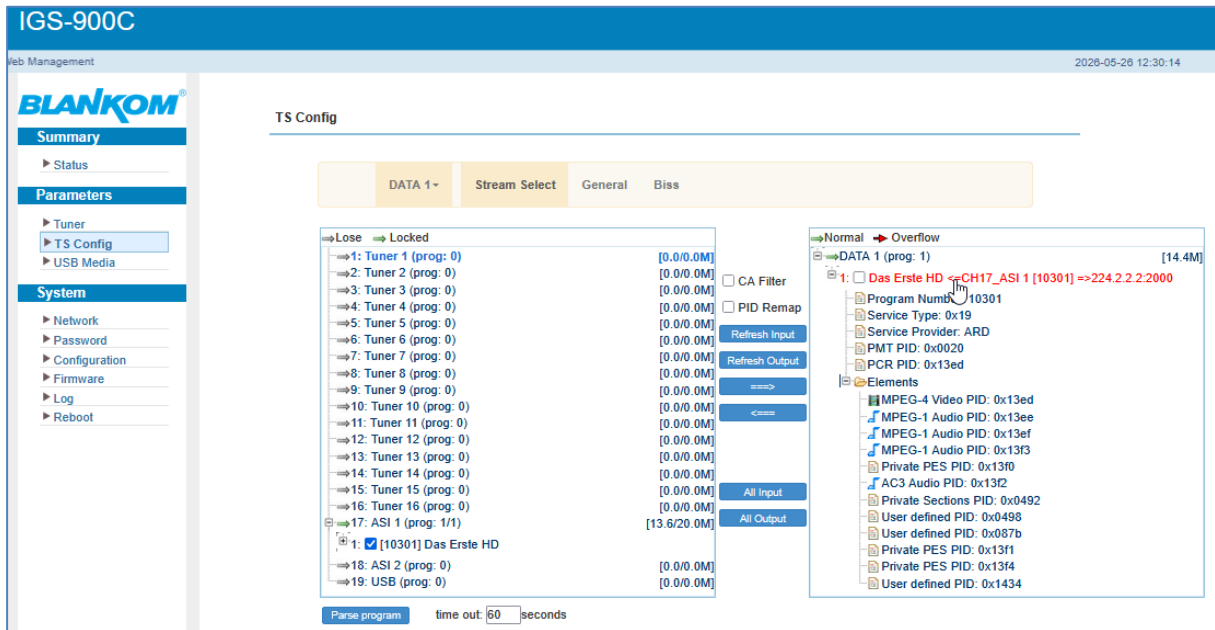

This is a slightly difference

between the old version and the new IGS-900/924 V3/4: The IP stream addresses in SPTS mode are integrated into the TV Service menu on the right side.

So, the IP output settings of each stream can be modified here. For RTSP-mode please note, that the receiver needs to be in the same subnet like the selected GbE Data port like here:

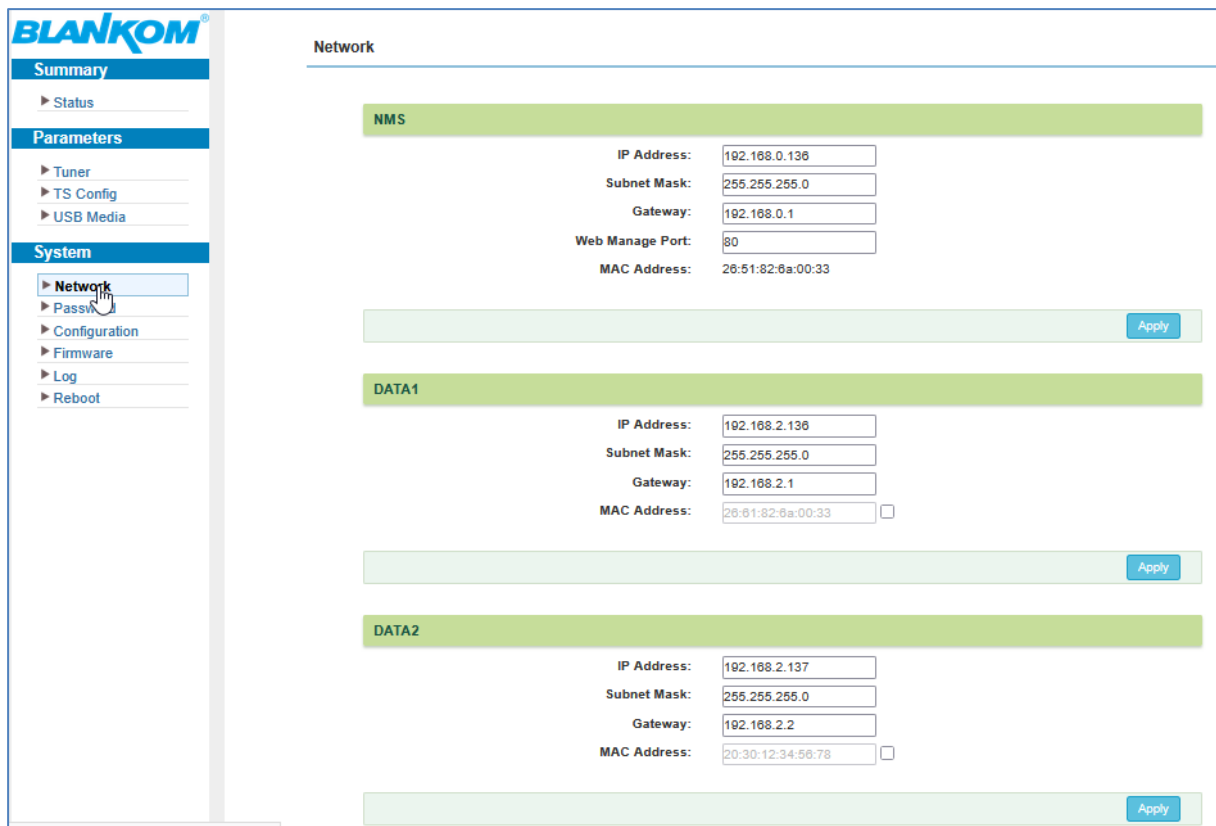

So, the first stream can be received by `rtsp://192.168.2.137:5000/1`
 But your receiver (PC/STB/TV with IGMP IPTV inside) needs to be part of it:

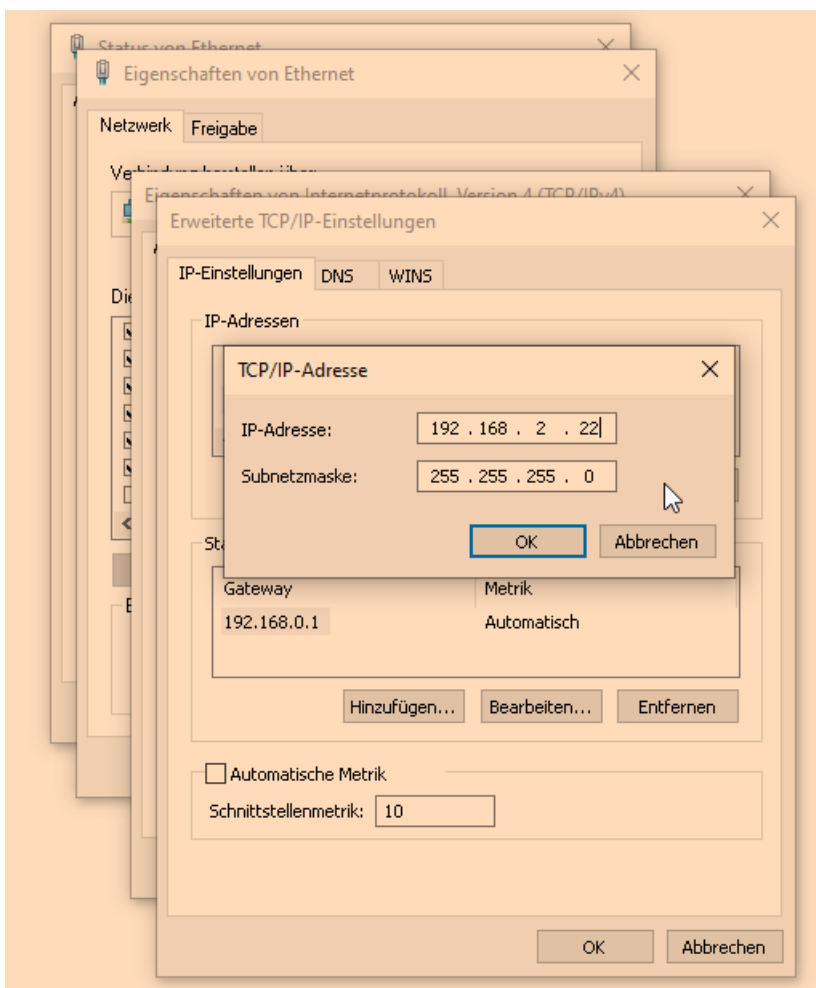



Rtsp://192.168.2.137:5000/2 is the address of the 2nd stream and so on until max.= 512 streams.

Back to the selection of the mode MPTS or SPTS streams:

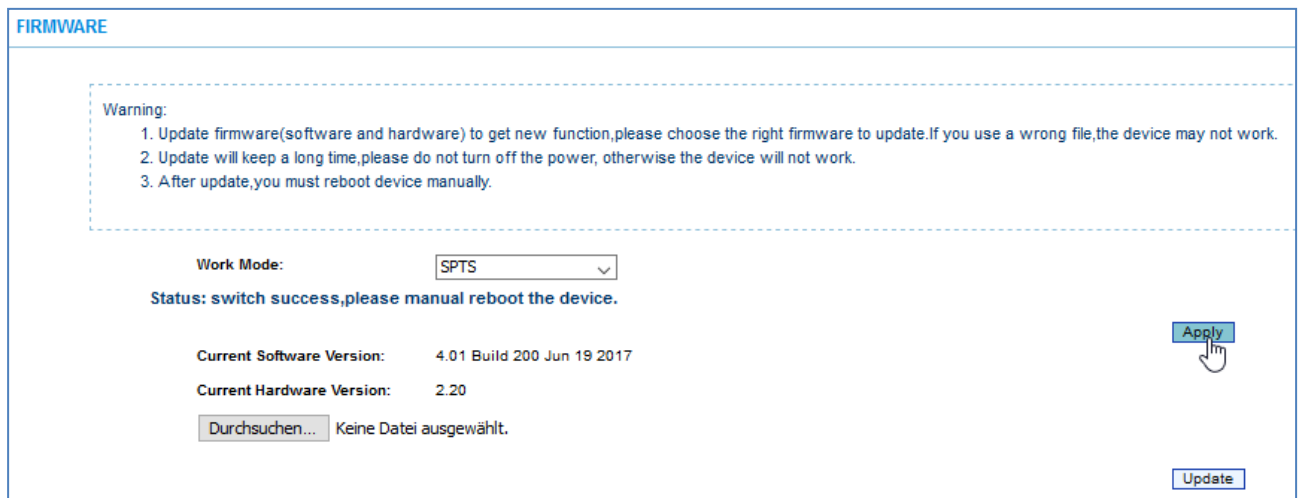

REAR -> OFF –ON

Power toggling performs a hard reset. The Reboot-Button might not work as HWC reset after changing so we recommend to use the Power-ON/OFF at the Front (or rear) ... dep. on Model*

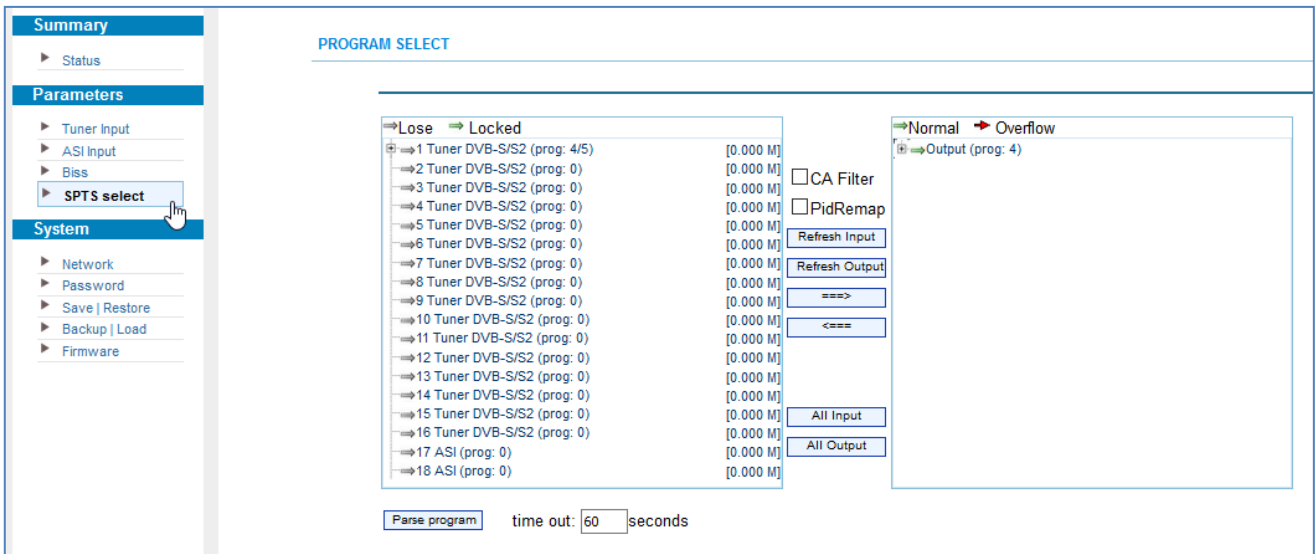

Success...

Backup config... recommended now. Because you changed the working mode those are not equal in MPTS/Bypass and SPTS. !!!

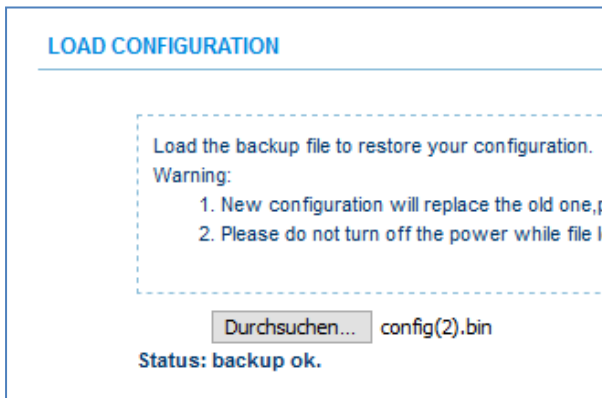

Network Setup:

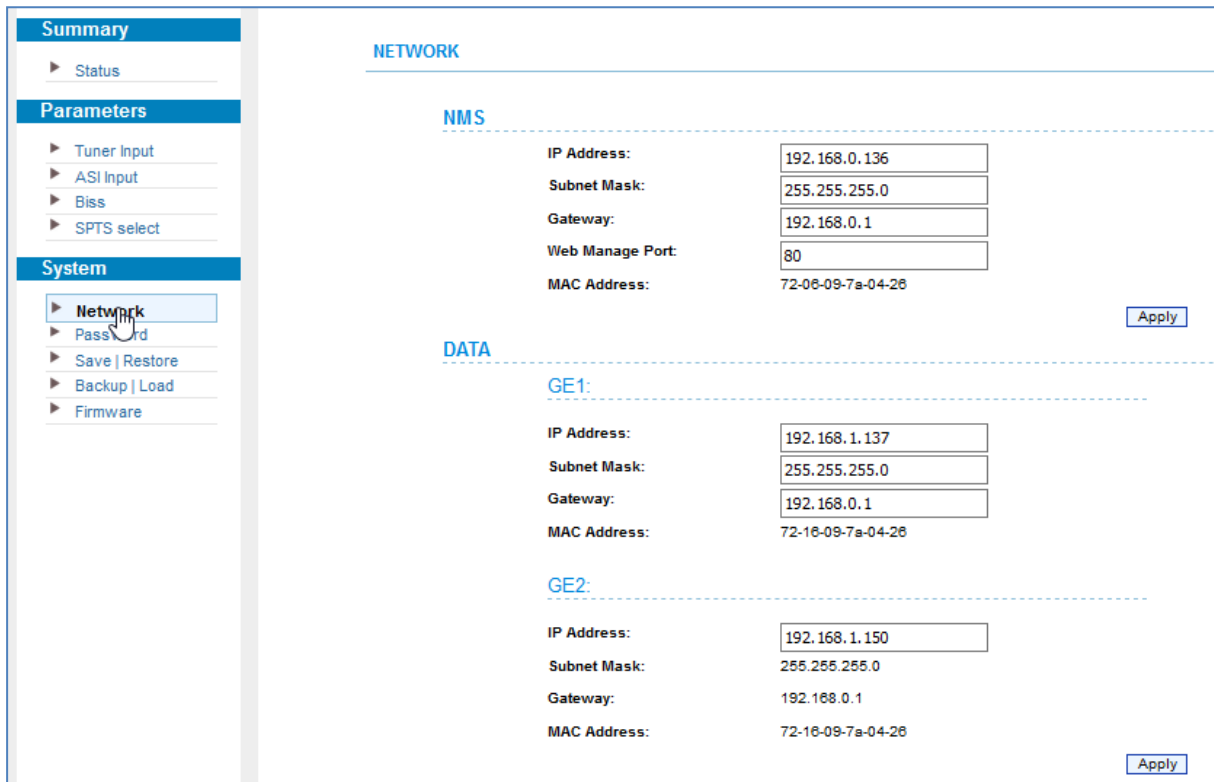

We assume that the user is familiar with IP settings and already knows his own system to connect the unit to. If you use the **Output Streaming: We recommend using 2 separate Switches!** At least a 100BaseT for the Management NMS RJ45 port and a second one with Gigabit Ethernet 10/100/1000BaseT with at least Layer 2+ with IGMP V2 features. Otherwise, you might flood your IP-Streaming network with unnecessary Data, which might overload connected IPTV STB's because they almost have only 100BaseT capacity (Never ones use 1GbE ports) but too many inputs into a STB can result in side effects. If you need to select a Switch, we recommend HP Procurve 2530 24G or 48G which are cost effective, easy to configure, can be trunked and supporting IGMP V2. If the switch needs routing functions, the bigger brother of this series might be the right choice.

Because to not accidentally put DATA and NMS port in the same sub-network, the data – port setting does not allow this by default. Usually, the DATA GbE Ports needing at least own and free IP addresses- otherwise the Switch or the receivers (i.e., IPTV STB's) cannot locate the source of the streams.

Note: For the GBE 1 and GBE 2 ports a security mechanism is installed to avoid setting them in the same IP-range like you have done for the NMS- port.

On GbE 1 the Gateway can be changed. GbE 2 would follow it automatically:

DATA

GE1:

IP Address:

Subnet Mask:

Gateway:

MAC Address:

GE2:

IP Address:

Subnet Mask:

Gateway:

MAC Address:

Changing the user-account:

Summary

- ▶ Status

Parameters

- ▶ Tuner Input
- ▶ ASI Input
- ▶ Biss
- ▶ SPTS select

System

- ▶ Network
- ▶ **Password**
- ▶ Save | Restore
- ▶ Backup | Load
- ▶ Firmware

PASSWORD

Modify the login name and password to make the device safely.If forget the name or password,you can reset it by keyboard. The default login name and password is "admin".Also please note the capital character and lowercase character.

Current UserName:

Current Password:

New UserName:

New Password:

Confirm New Password:

Change it to your needs, but do not forget the password otherwise you would need to reset the unit with the Front-panel RESET switch (press it min. 10...15 sec) to factory default.

Attention for CATV-Tuner setups:

DVB-C / T Tuning is slightly different and you need to enter the center- frequency of the to

be received DVB-C/QAM channel. The tuner will detect the inside-channel values.

NOTE: a comma in the frequency like 624,25 MHz has to be entered in AMERICAN STYLE as

a ' Instead the ,'

Tuner-Setup SAT:

The screenshot shows a web interface for configuring satellite tuners. On the left, there are navigation tabs: Summary, Parameters, and System. The Parameters tab is active, showing a list of 9 tuners. Each tuner entry includes a number (1-9), a type (DVB-S/S2), and a status indicator (Quality and Strength bars, and a color-coded dot). Tuner 1 is active, showing a quality of 30% and strength of 68%, with a data rate of 31.709 Mbps. The other tuners are inactive, showing 0% quality and strength, and 0.000 Mbps data rate. Each entry has an 'Edit' button to its right.

Using a Multiswitch with more than one SAT-position and > 16 outputs: You can set every single Tuner Input individually.

Using a SAT-Splitter: Be carefully, active splitter needs at least one 13V...18V DC connection to it to operate. You should avoid to switch on V/H polarization Voltage 13/18V on every Input port. The active splitter would pass the 13V or 18V to the Multiswitch and assigning the fixed polarization to the Multiswitch. So, all selected Transponders should be either in Vertical (13V) or Horizontal (18V) position.

Passive splitters should be used with DC Passthrough and the Voltage should be passed only once as well.

We recommend to check www.lyngsat.com or www.satbeams.org for correct settings.

Example:

<https://www.lyngsat.com/Astra-1KR-1L-1M-1N.html>

LyngSat

Astra 1KR/1L/1M/1N at 19.2°E

[Asia](#) | [Main](#) | [Europe](#) | [Europe P](#) | [Europe HD](#) | [Europe](#) | [UHD](#) | [Headlines](#) | [Launches](#) | [Atlantic](#)

20.0°E <C> 10.0°E | [SatTracker](#) | [LyngSat Maps](#) | 21.5°E <Ku> 16.0°E

[Astra 1KR/1L/1M/1N](#) | [Astra 1KR](#) | [Astra 1L](#) | [Astra 1M](#) | [Astra 1N](#)

Azimuth & elevation in Hanover, Germany: 168.1° & 29.5°
 The EIRP values are for Hannover, Germany

Frequency Beam EIRP (dBW)	Provider Name Channel Name	System Encryption	SR-FEC SID-VPID	ONID-TID C/N lock APID Lang.	Source Updated
10714 H tp 49 Europe 51		DVB-S2	23500-3/4 8PSK	1-1049	D Shimoni 170629
	HDR tests	HEVC/UHD	301 101	AAC	
	HFR tests	HEVC/UHD	302 257	258 AAC	
10729 V tp 50 Europe 51	Movistar+	DVB-S2 MPEG-4/HD Nagravision 3	22000-2/3 8PSK	1-1050 6,6	N Schlammer 170531
10744 H tp 51 Europe 51	ARD Digital	DVB-S	22000-5/6	1-1051 6,5	T Viererbe 161018
	Tagesschau 24	T F S	28721 101	102 G	
	One	T F	28722 201	202 G 203 orig 206 G AC3	
	ARTE Deutsch	T F	28724 401	402 G 408 F	

a-1L.html

We are using a 1-8 active splitter here and so we have to take care, that the first 8 inputs will be setup to tune the same polarization and set the first Input to it **LOW-Band =9750 MHz LNB-IF frequency** (while **HIGH-band** is almost 10600.000MHz using 22KHz signal):

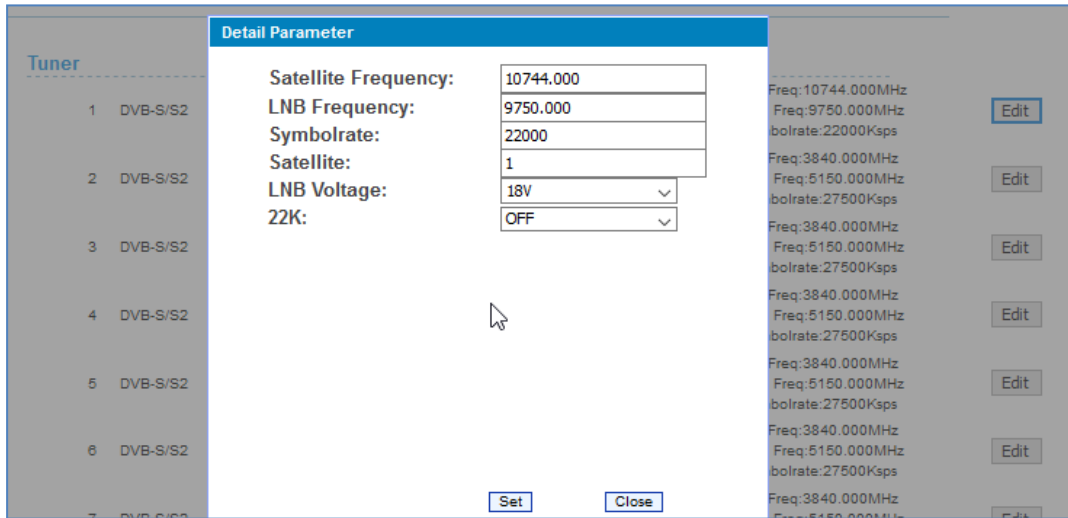

The next is:

Channel	Service	Modulation	Frequency	Symbol Rate	Roll-off	Other
10891 H	ARD Digital	DVB-S2	10891	22000-2/3	1-1061	6.6
	RBB Brandenburg (19.30-20.00)	MPEG-4/HD	10350	5301	5302 G	5303 orig 5306 G AC3
	RBB Berlin	MPEG-4/HD	10351	5311	5312 G	5313 orig 5316 G AC3
	MDR Fernsehen Sachsen (19.00-19.30 & Wed 21.15-21.45)	MPEG-4/HD	10352	5321	5322 G	5323 orig 5326 G AC3
	MDR Fernsehen Sachsen-Anhalt	MPEG-4/HD	10353	5331	5332 G	5333 orig 5336 G AC3
	MDR Fernsehen Thüringen (19.00-19.30 & Wed 21.15-21.45)	MPEG-4/HD	10354	5341	5342 G	5343 orig 5346 G AC3
	HR Fernsehen	MPEG-4/HD	10355	5351	5352 G	5353 orig 5356 G AC3

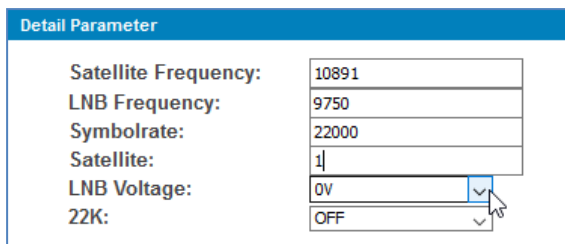

-> Only 1x 18V supplying is enough by using

the active (or passive) Splitter. Be patient, the unit's WEBIF will take some time to update the Information:

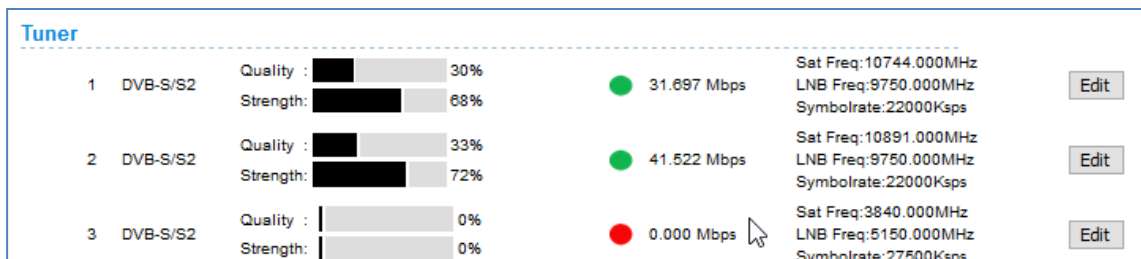

You can now proceed with the other 16 Inputs. (Rem.: C-Band-LNB-Freq=5150MHz... preset in the Menu)

Detail Parameter	
Satellite Frequency:	11362
LNB Frequency:	9750
Symbolrate:	22000
Satellite:	1
LNB Voltage:	0V
22K:	OFF

Following 7 tuner INPUTS at the splitter do

not need DC.

Example to tune to a second Satellite, here with connected Input no. 9 directly to a Multiswitch w/o using a splitter:

LyngSat

Eutelsat Hot Bird 13B/13C/13E at 13.0°E

Asia	Main	Europe	Europe P	Europe HD	Europe	UHD	Headlines	Launches	Atlantic
20.0°E <C> 10.0°E		HD SatTracker LyngSat Maps				16.0°E <Ku> 10.0°E			
Eutelsat Hot Bird 13B/13C/13E Eutelsat Hot Bird 13B Eutelsat Hot Bird 13C Eutelsat Hot Bird 13E									
Azimuth & elevation in Hanover, Germany: 175.9° & 30.0° The EIRP values are for Hannover, Germany Eutelsat Hot Bird 13B/13C/13E © LyngSat, last updated 2017-07-03 https://www.lyngsat.com/Eutelsat-Hot-Bird-13B-13C-13E.html									
Frequency Beam EIRP (dBW)		Provider Name Channel Name		System Encryption	SR-FEC SID-VPID	ONID-TID C/N lock APID Lang.	Source Updated		
10719 V tp 110 Wide 52-53		NC+	P	DVB-S2 Conax Mediaguard 2 Nagravision 3 Viaccess 3.0	27500-3/4 8PSK	318-11000 7.9	N Schlammer P Piotrowski M Al-Taie 170518		

choosing HIGH-Band (the High- and Low-Band are seperated. High band starts at 11700 MHz), 12437 MHz, 10600 SAT-IF, 29900 SBR

12437 H tp 87 Wide 52-53		IRIB		DVB-S2	29900-3/4 QPSK	318-8700 4.0			
		IRINN	F	MPEG-4	7906 1060	1061 Fa AAC			
		Quran TV (Iran)	F	MPEG-4	7908 1080	1081 Fa AAC			
		IFilm Arabic	F S	MPEG-4	7914 1140	1141 Fa AAC 1142 A AAC			
		Nasim	F	MPEG-4	7920				
		Jame-Jam TV Network	F	MPEG-4	7921				
		[test card]		MPEG-4	7925				
		Sahar Francophone (13.30-17.00 & 21-09)	F S	MPEG-4	7926				
		Sahar Bosnian (09.00-13.30 & 17-21)	F S	MPEG-4	7926				
		Sahar Azeri	F S	MPEG-4	7927				
		Sahar Urdu	F S	MPEG-4	7928				
		Sahar Kurdish	F S	MPEG-4	7929				
		Alkawthar TV	F	MPEG-4	7930				
		Press TV	F S	MPEG-4/HD	7931 1310	1311 E			
		Hispan TV	F S	MPEG-4	7932 1320	1321 Sp			
	IFilm English	F S	MPEG-4	7933 1330	1331 E 1332 Fa				
	Radio Iran	F S		7951	1511 Fa AAC				
	Radio Payam	F S		7952	1521 Fa AAC				
	Radio Javan	F		7953	1531 Fa AAC				
	Radio Maaref	F		7954	1541 Fa AAC				

Detail Parameter	
Satellite Frequency:	12437
LNB Frequency:	10600
Symbolrate:	29900
Satellite:	2
LNB Voltage:	18V
22K:	ON

SET!

9	DVB-S/S2	Quality : <div style="width: 30%; height: 10px; background: linear-gradient(to right, black, grey);"></div> 30%	Strength: <div style="width: 62%; height: 10px; background: linear-gradient(to right, black, grey);"></div> 62%	● 38.641 Mbps	Sat Freq:12437.000MHz LNB Freq:10600.000MHz Symbolrate:29900Ksps Sat Freq:3840.000MHz	Edit
		Quality : <div style="width: 0%; height: 10px; background: linear-gradient(to right, black, grey);"></div> 0%				

Remark:

We *do not* recommend to *use* the *Loop-outputs* to serve the next RF Input because of it is too much attenuation - mostly. The reception might fail because of a too weak signal input. Now we have configured 9 of 16 Inputs:

Tuner			
1	DVB-S/S2	Quality : 30% Strength: 68%	31.709 Mbps Edit
2	DVB-S/S2	Quality : 34% Strength: 72%	41.583 Mbps Edit
3	DVB-S/S2	Quality : 32% Strength: 68%	41.464 Mbps Edit
4	DVB-S/S2	Quality : 30% Strength: 74%	32.741 Mbps Edit
5	DVB-S/S2	Quality : 30% Strength: 70%	38.510 Mbps Edit
6	DVB-S/S2	Quality : 31% Strength: 70%	31.694 Mbps Edit
7	DVB-S/S2	Quality : 30% Strength: 68%	30.991 Mbps Edit
8	DVB-S/S2	Quality : 31% Strength: 68%	32.974 Mbps Edit
9	DVB-S/S2	Quality : 30% Strength: 62%	39.436 Mbps Edit

DVB-C Tuning (see also end of the document IGS-900C):

Of course, you need the proper DVB-tuner installed instead of SAT: Select your RF-Mode:



Then we enter the known parameter: Modulation here DVB-C-J83A/C, Centre Freq.: 650MHz (unusual = no Cenelec-Channel-Plan), 6850 SR, 256QAM constellation, assure the proper dBm (dBµV) Input values in the Coax-cable...

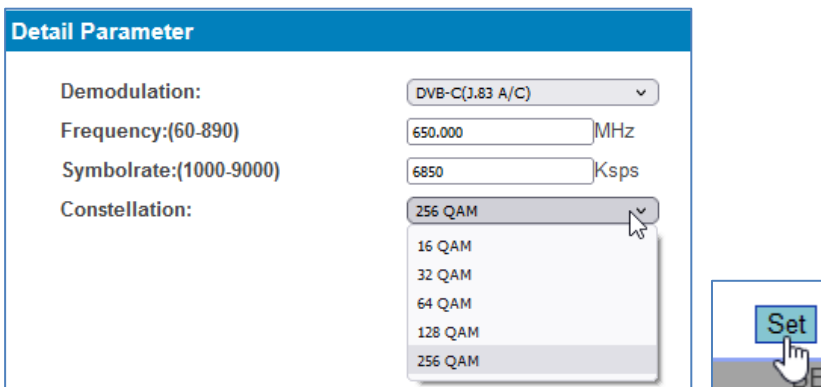

Tuner

1	DVB-C(J.83 A/C)	Quality : ██████████ 99%	C/N: 36.00 dB	8.586 Mbps	Freq:650.000MHz	<input type="button" value="Edit"/>
		Strength: ██████████ 84%	Power: -15.50 dBm			
			BER: 0.00e+00			
			C/N: 0.00 dB			

Example here with only one TV Service from our encoder Modulator:
 Parse the input to get the content information:

PROGRAM SELECT

Summary
 ▶ Status

Parameters
 ▶ Tuner Input
 ▶ ASI Input
 ▶ TS Config
 ▶ Biss
 ▶ SPTS select

System

→ Lose → Locked			Normal → Overflow
→1 Tuner DVBC (prog: 0)	[11.438 M]	<input checked="" type="checkbox"/> CA Filter	→ Output (prog: 0)
→2 Tuner DVBC (prog: 0)	[0.000 M]	<input checked="" type="checkbox"/> PidRemap	
→3 Tuner DVBC (prog: 0)	[0.000 M]	<input type="button" value="Refresh Input"/>	
→4 Tuner DVBC (prog: 0)	[0.000 M]	<input type="button" value="Refresh Output"/>	
→5 Tuner DVBC (prog: 0)	[0.000 M]		
→6 Tuner DVBC (prog: 0)	[0.000 M]		
→7 Tuner DVBC (prog: 0)	[0.000 M]		
→8 Tuner DVBC (prog: 0)	[0.000 M]		

Switch off PIDRemap and CA filter if your Input RF does not contain encrypted channel PIDs and does not overlap in PID-numbers with other to be received RF Channels in DVB-C/T/T2 or ISDB-Tb or ...

time out: seconds

→ Lose → Locked			Normal → Overflow
→1 Tuner DVBC (prog: 0/1)	[11.521M]	<input type="checkbox"/> CA Filter	→ Output (prog: 0)
→2 Tuner DVBC (prog: 0)	[0.000 M]	<input type="checkbox"/> PidRemap	
→3 Tuner DVBC (prog: 0)	[0.000 M]		
→4 Tuner DVBC (prog: 0)	[0.000 M]		

Select and stream it right:

→1 Tuner DVBC (prog: 0/1)	[7.866 M]	<input type="checkbox"/> CA Filter	Normal → Overflow
1: <input checked="" type="checkbox"/> BLANKOM HD1		<input type="checkbox"/> PidRemap	→ Output (prog: 0)
Program Number: 474		<input type="button" value="Refresh Input"/>	
Service Type: 0x01		<input type="button" value="Refresh Output"/>	
Service Provider: BLANKOM		<input type="button" value="===>"/>	
PMT PID: 0x0020		<input type="button" value="<==="/>	
PCR PID: 0x0032			
Elements			
MPEG-4 Video PID: 0x0030			
MPEG-2 Audio PID: 0x0031			

Click on that

Normal → Overflow
→ Output (prog: 1)
1: <input type="checkbox"/> BLANKOM HD1 => Tuner1
Program Number: 474

and you can modify what you like:

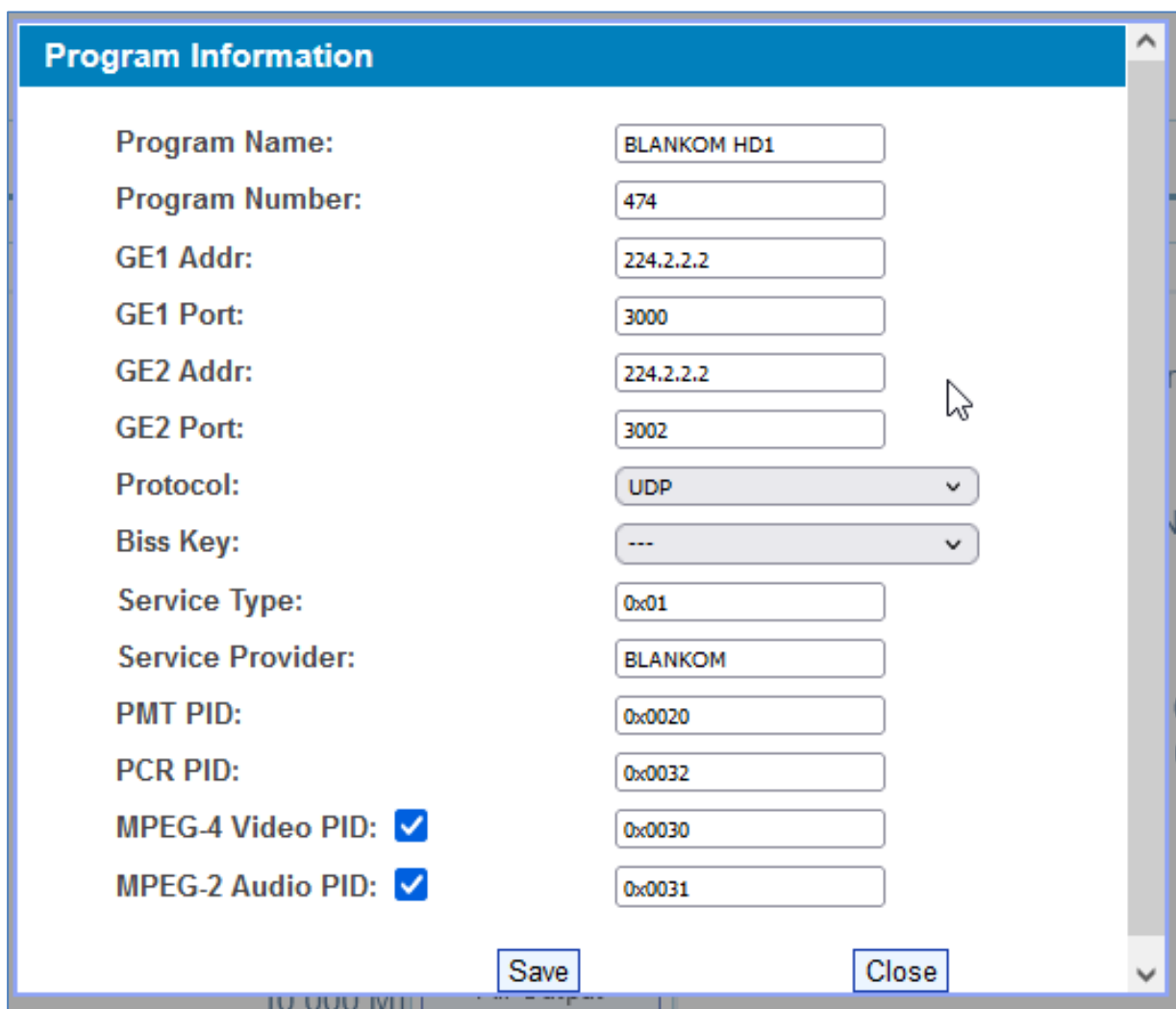
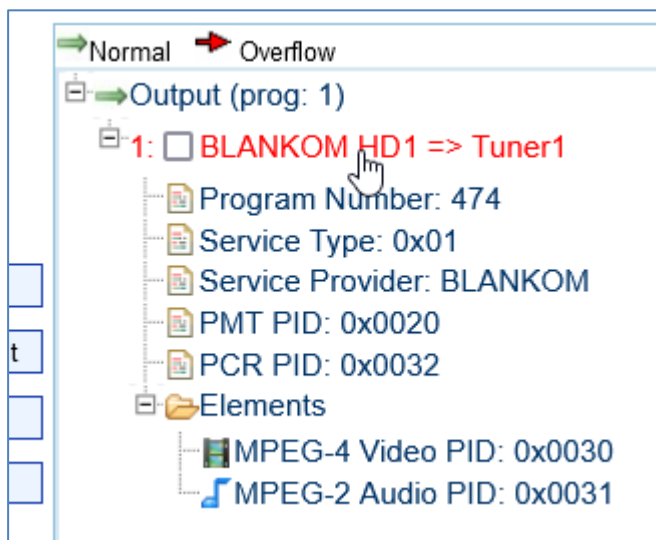

We recommend not to use same MultiCast-IP Addresses but also different ones and so the ports as well: Bad example for GBE1+2:

GE1 Addr:	<input type="text" value="224.2.2.2"/>
GE1 Port:	<input type="text" value="3000"/>
GE2 Addr:	<input type="text" value="224.2.2.2"/>
GE2 Port:	<input type="text" value="3002"/>

Note: The both GbE outputs are some kind of mirrors and are not independent from each other.

Note Samsung Hospitality TV's like to start with 225.x.x.x instead of 224.x.x.x!

So 225.0.0.1:10001 ... 225.0.0.2:10002 ... is a good idea.

Of course you can have other inputs like ASI to demultiplex and stream to UDP Multicast. Be sure you are able to switch ON your IGMP-management in your GbE Switches to not flood the network with Multicast's!!!

ASI-INPUT(s):

As soon as you connect the ASI IN-Ports:

Now we have configured 9 SAT + 2 ASI Inputs and like to stream selected Services to IP out:

SPTS output Settings: (Also see the note above)

CA Filter and PID-Remap are ON by default.

CA-Filter: If you do not need to filter decrypted unnecessary EMM/ECM PIDs from the

Input Streams, please uncheck them.

PID Remapping isn't almost necessary for SPTS streaming. In MPTS mode it can avoid overlapping PID-Re-Multiplex problems. DVB-professionals know that ...

You need to parse every single Input content by selecting the Input (Tuner/ASI) and PARSE it:

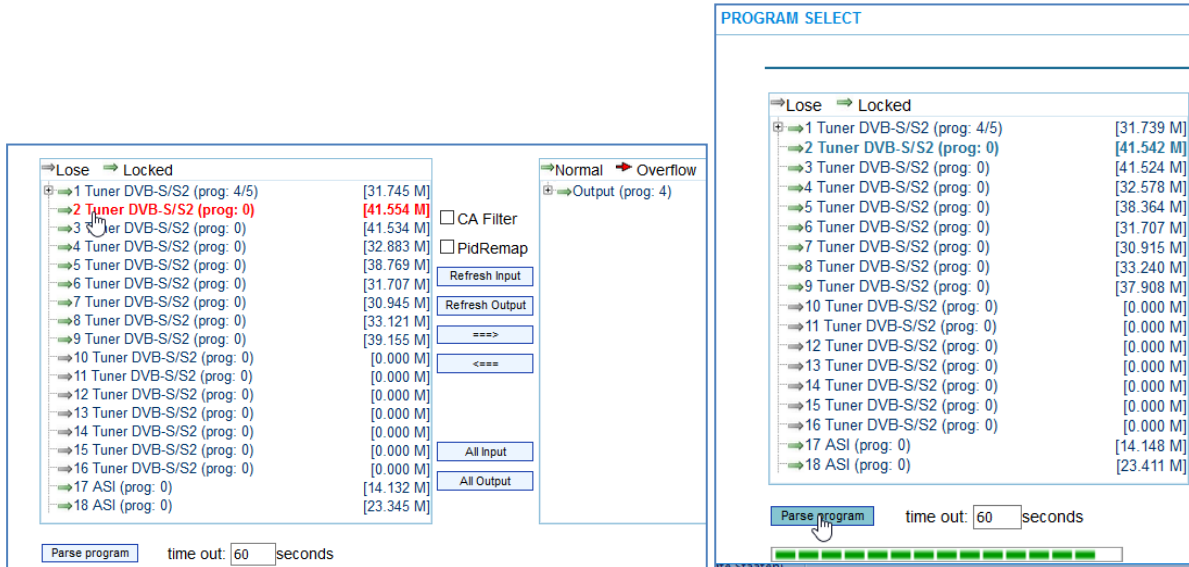

see the content and more info:

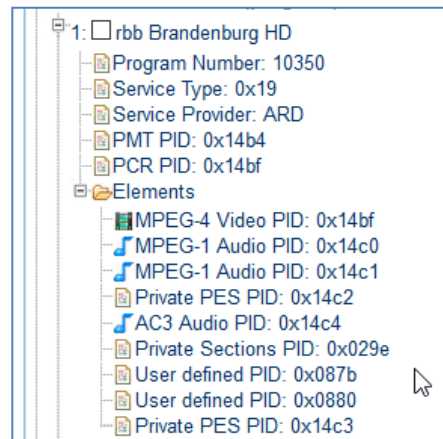

Now we sent this to the output on the right side:

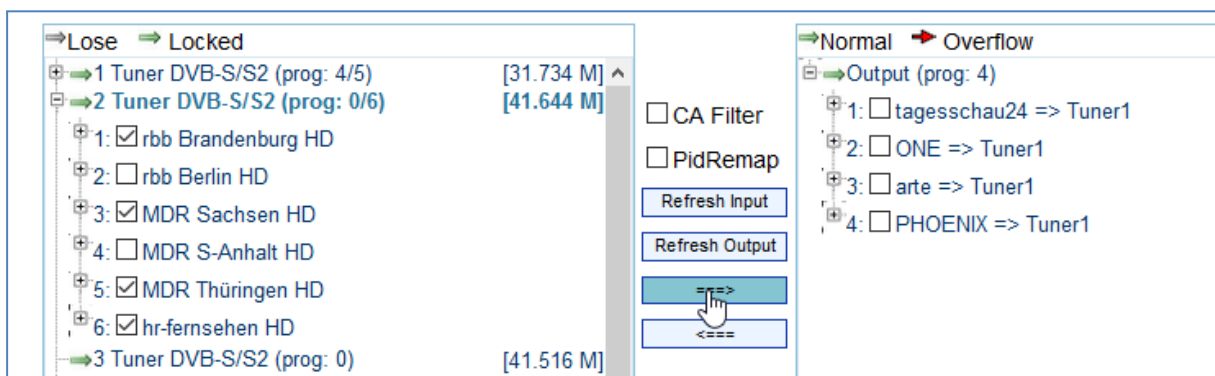

proceed with all Inputs to generate your favorite Streams...
 Finally, you'll get an overview how many you have selected from which input left to the outputs right:

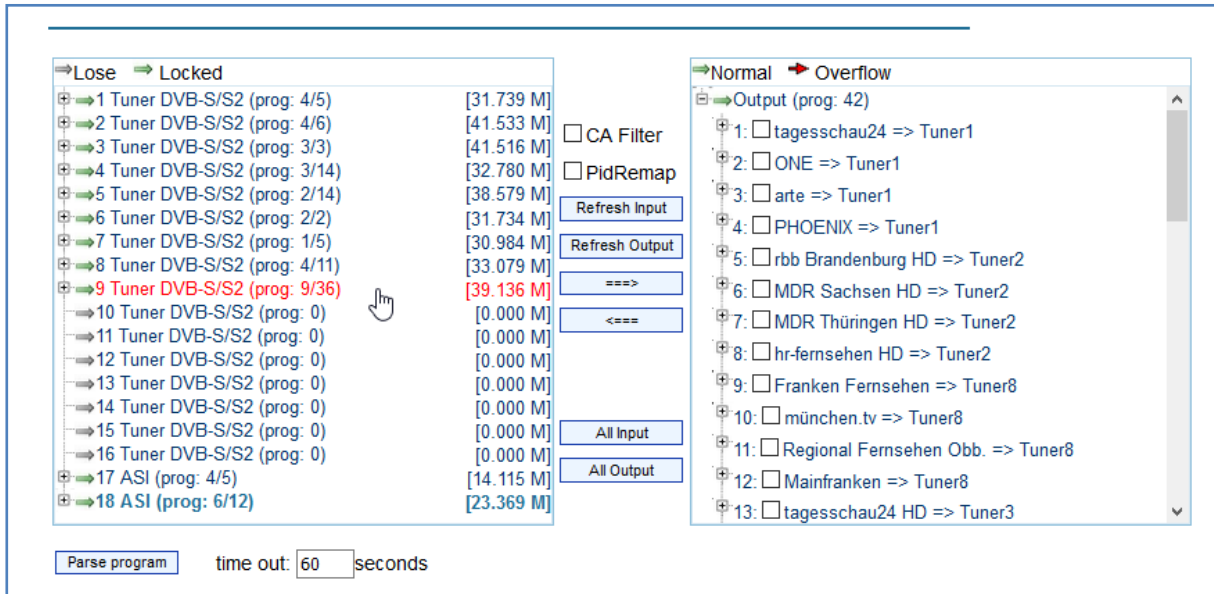

Now it's time to configure your

Stream output settings:

by selecting the output service

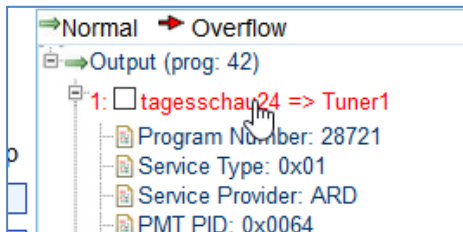

The **RTSP-streams** can be unicast received by GBE1 out or GBE2 out:
 rtsp://192.168.2.137:5000/1 ... /512 (max streams in SPTS) and GBE2: rtsp://192.168.2.150:5000/1 ... /512 while in MPTS mode
 The single streams are /1 ... /16 only, but consider which output you have directed them to. Depending on Model!!!

a popup will follow:

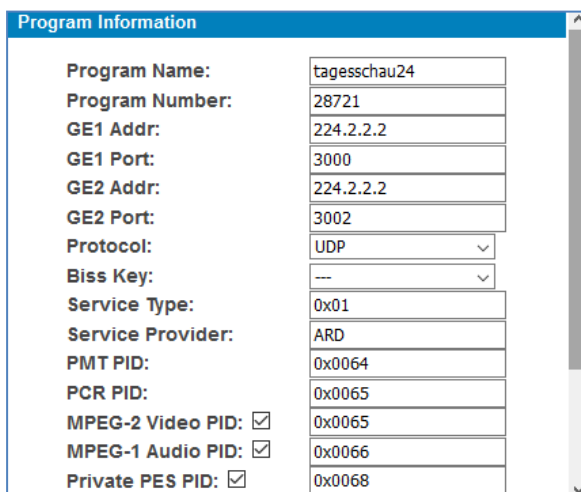

Details of the services are shown and can be partly modified as well as the streaming addresses and protocols.
 The default values can be used, they are automatically assigned.

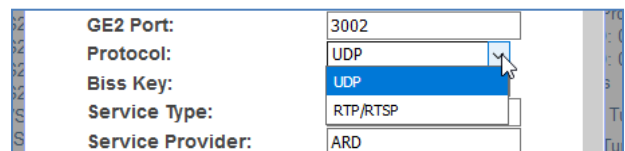

scrolling down:

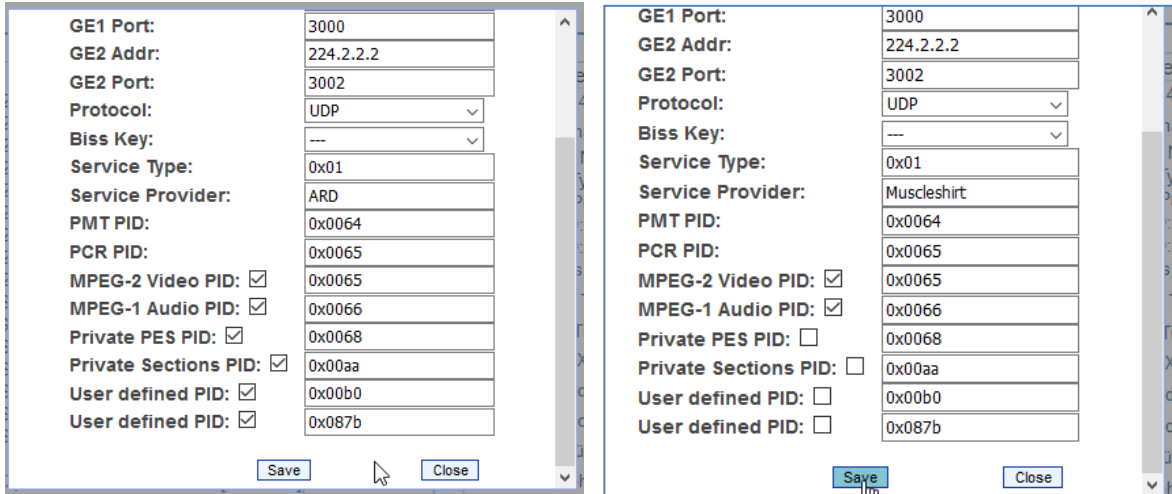

Proceed with all of them, filter unwanted PIDs, I hope we know what you are doing ...
SAVE and go.

Now it is Time to **SAFE** yourself before your kid is cutting the power source accidentally:

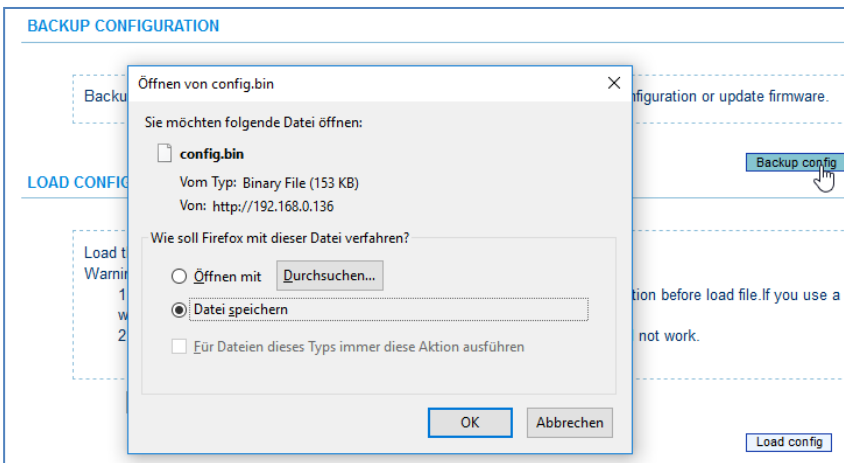

Addon: BISS decryption:

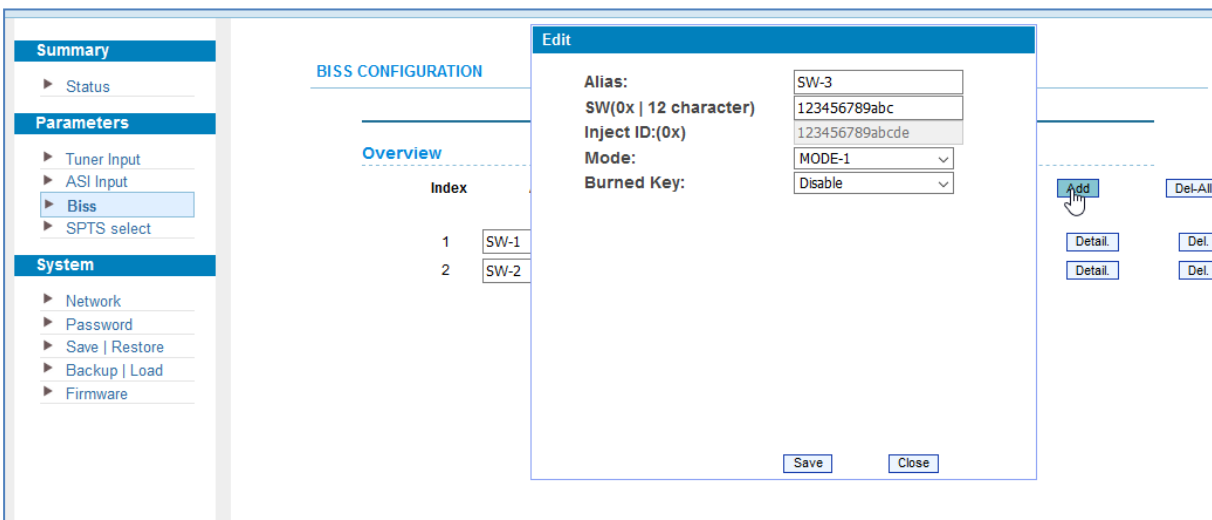

You can insert different BISS keys and finally select the outputs, which should be "de-biss'ed" before they are streamed out:

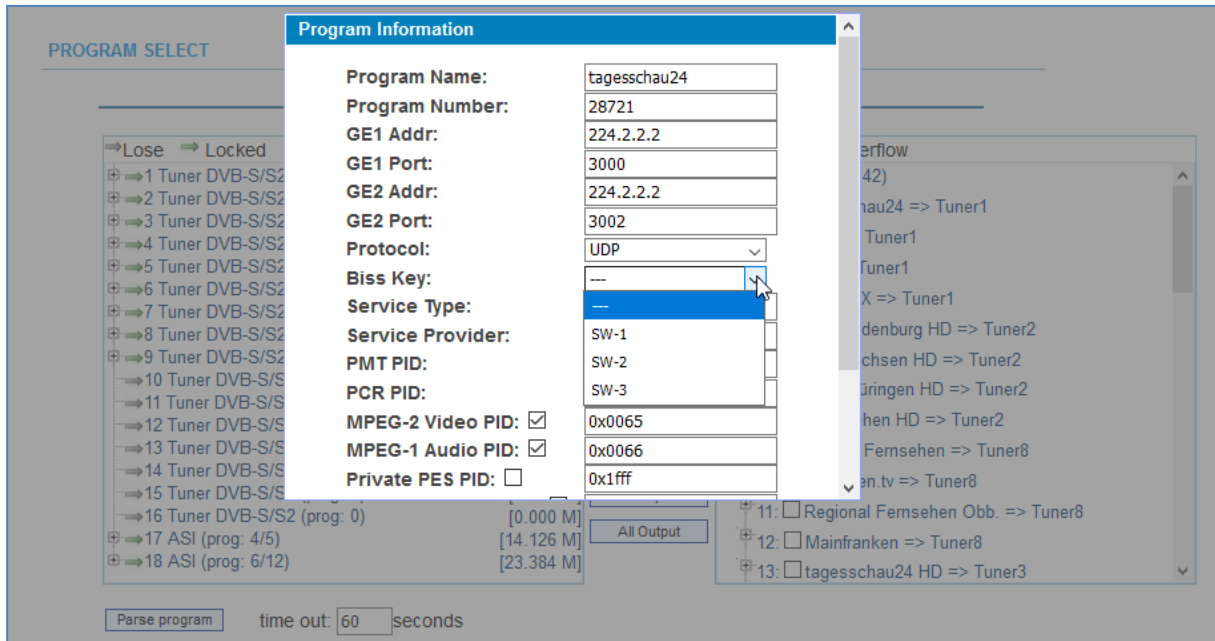

Check the streams:

Inputs:

Tuner							
1	DVB-S/S2	Quality : 30%	Strength: 68%		31.673 Mbps	Sat Freq:10744.000MHz LNB Freq:9750.000MHz Symbolrate:22000Ksps	Edit
2	DVB-S/S2	Quality : 34%	Strength: 72%		41.592 Mbps	Sat Freq:10891.000MHz LNB Freq:9750.000MHz Symbolrate:22000Ksps	Edit
3	DVB-S/S2	Quality : 32%	Strength: 68%		41.450 Mbps	Sat Freq:11053.000MHz LNB Freq:9750.000MHz Symbolrate:22000Ksps	Edit
4	DVB-S/S2	Quality : 30%	Strength: 74%		32.611 Mbps	Sat Freq:11244.000MHz LNB Freq:9750.000MHz Symbolrate:22000Ksps	Edit
5	DVB-S/S2	Quality : 30%	Strength: 70%		38.429 Mbps	Sat Freq:11273.000MHz LNB Freq:9750.000MHz Symbolrate:22000Ksps	Edit
6	DVB-S/S2	Quality : 31%	Strength: 70%		31.691 Mbps	Sat Freq:11362.000MHz LNB Freq:9750.000MHz Symbolrate:22000Ksps	Edit
7	DVB-S/S2	Quality : 30%	Strength: 68%		31.009 Mbps	Sat Freq:11391.000MHz LNB Freq:9750.000MHz Symbolrate:22000Ksps	Edit
8	DVB-S/S2	Quality : 31%	Strength: 68%		33.135 Mbps	Sat Freq:11523.000MHz LNB Freq:9750.000MHz Symbolrate:22000Ksps	Edit
9	DVB-S/S2	Quality : 30%	Strength: 62%		40.291 Mbps	Sat Freq:12437.000MHz LNB Freq:10600.000MHz Symbolrate:29900Ksps	Edit

SPTS outputs:

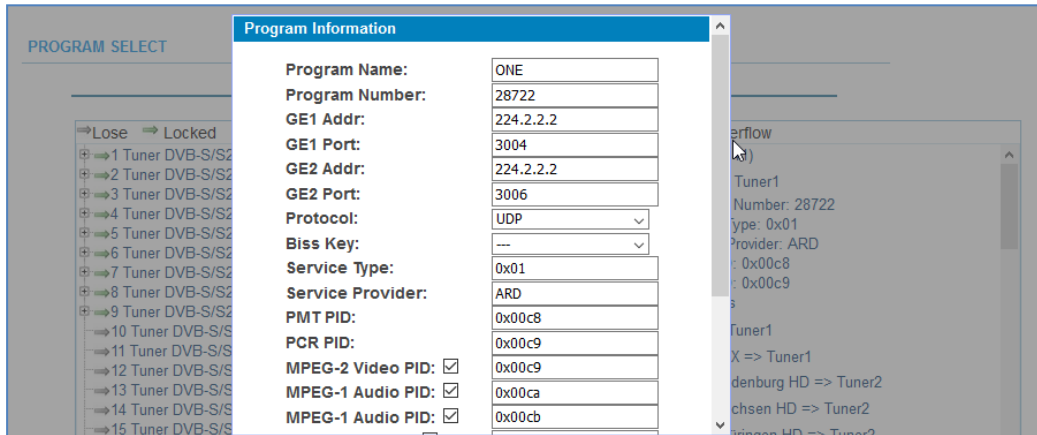
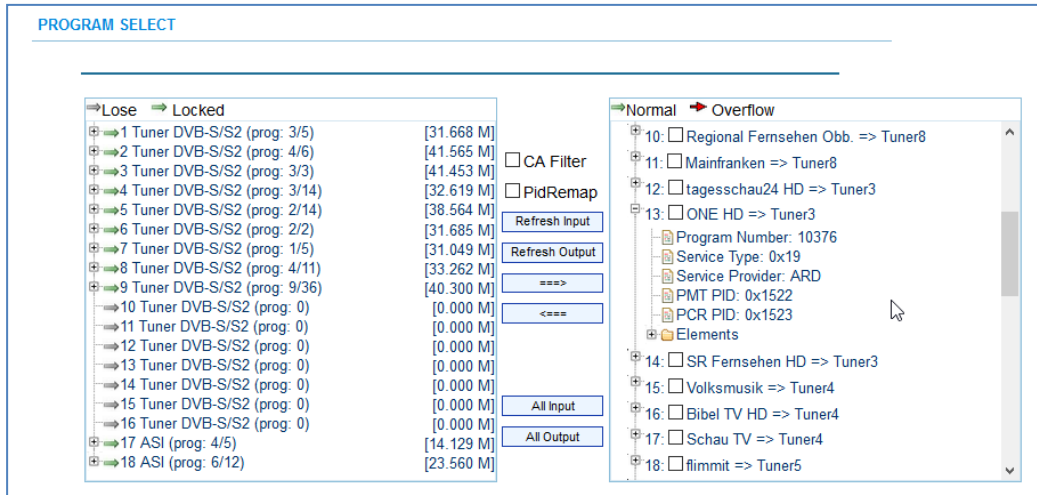

Using Dektec Fantasi with stream-expert, GE2 disconnected,
 1 = ONE (SD) = udp://224.2.2.2:3004
 13= ONEHD = udp://224.2.2.2:3052 and others...

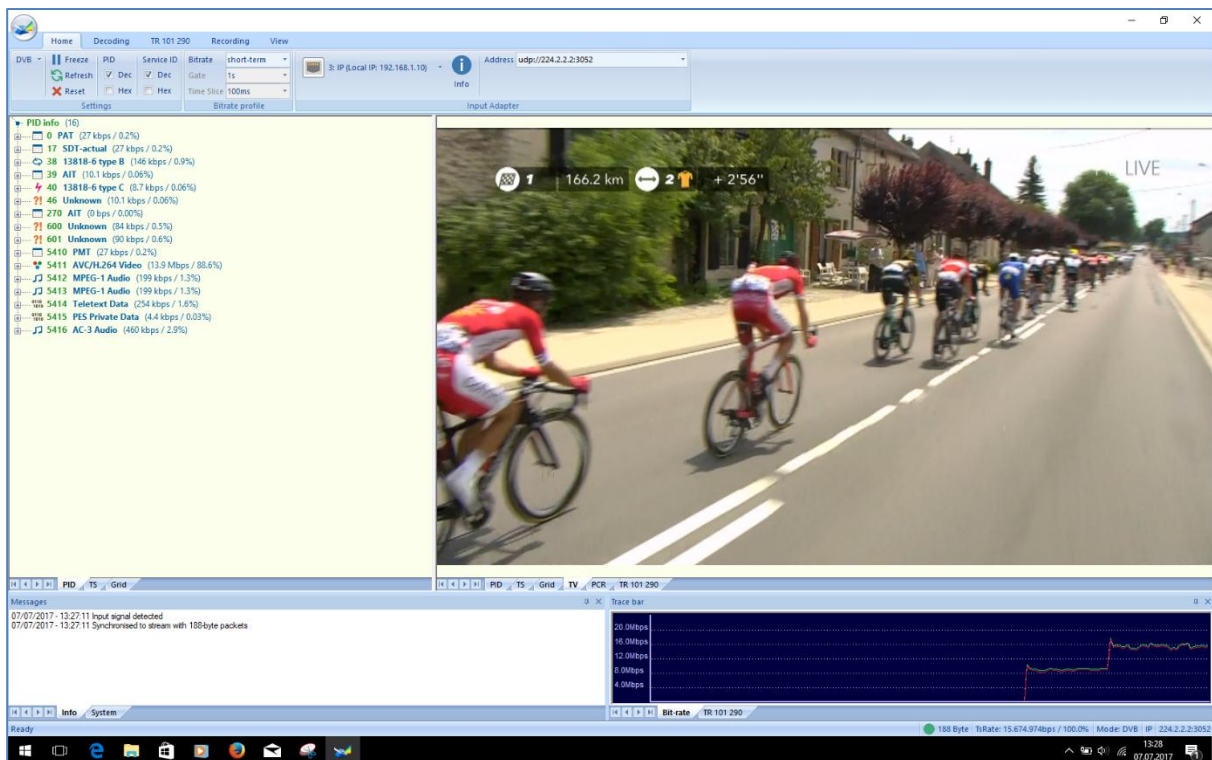

Almost OK...

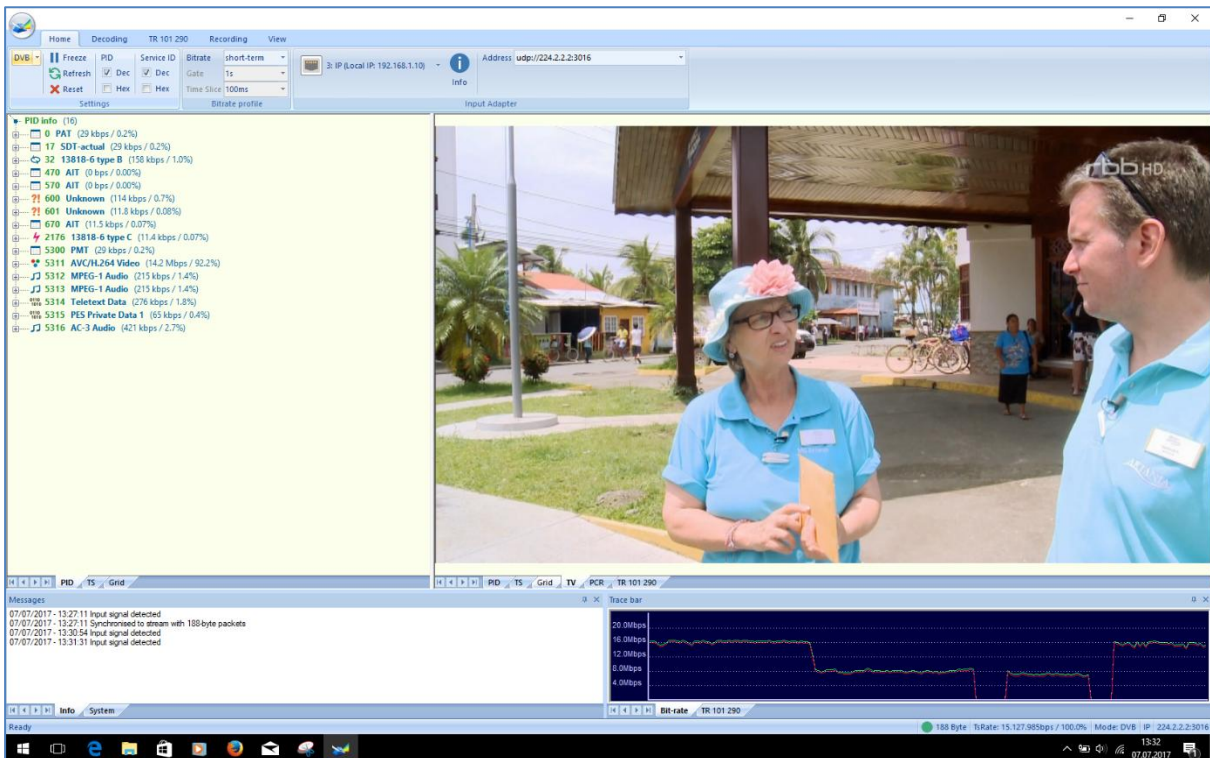
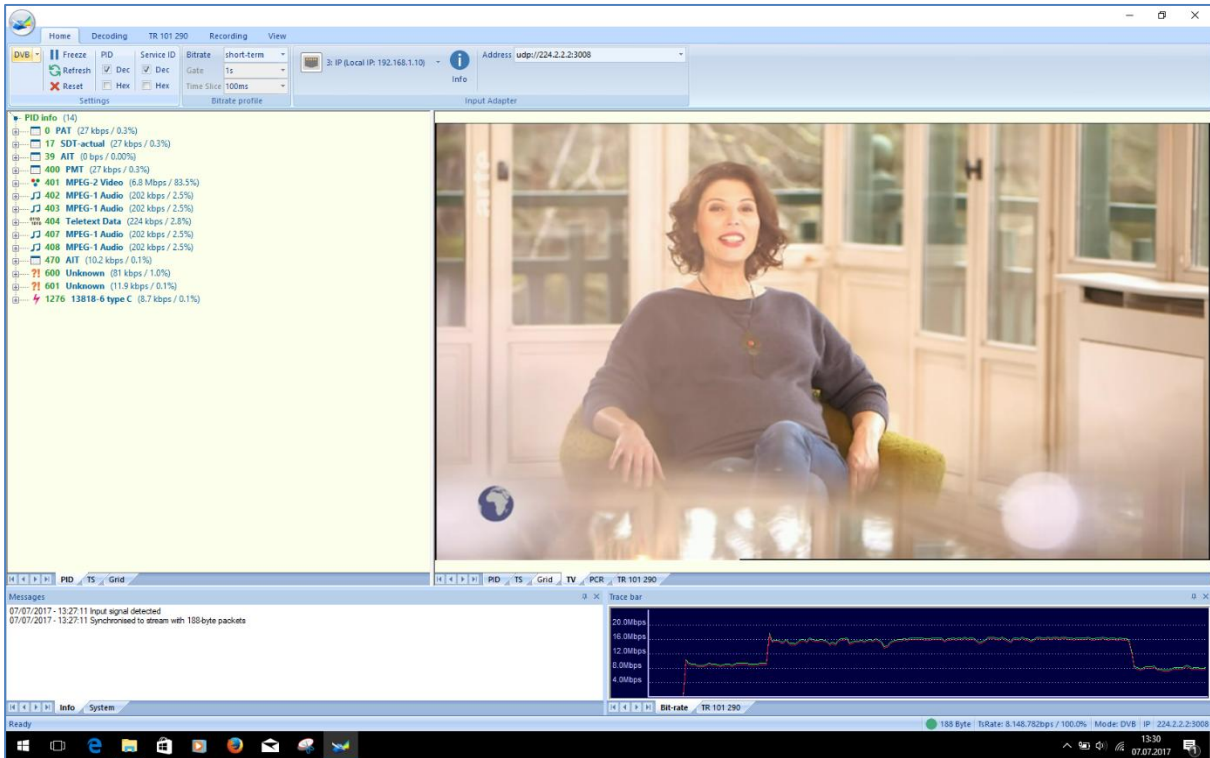

RTSP screenshots: first is in MPTS, 2nd a SPTS stream

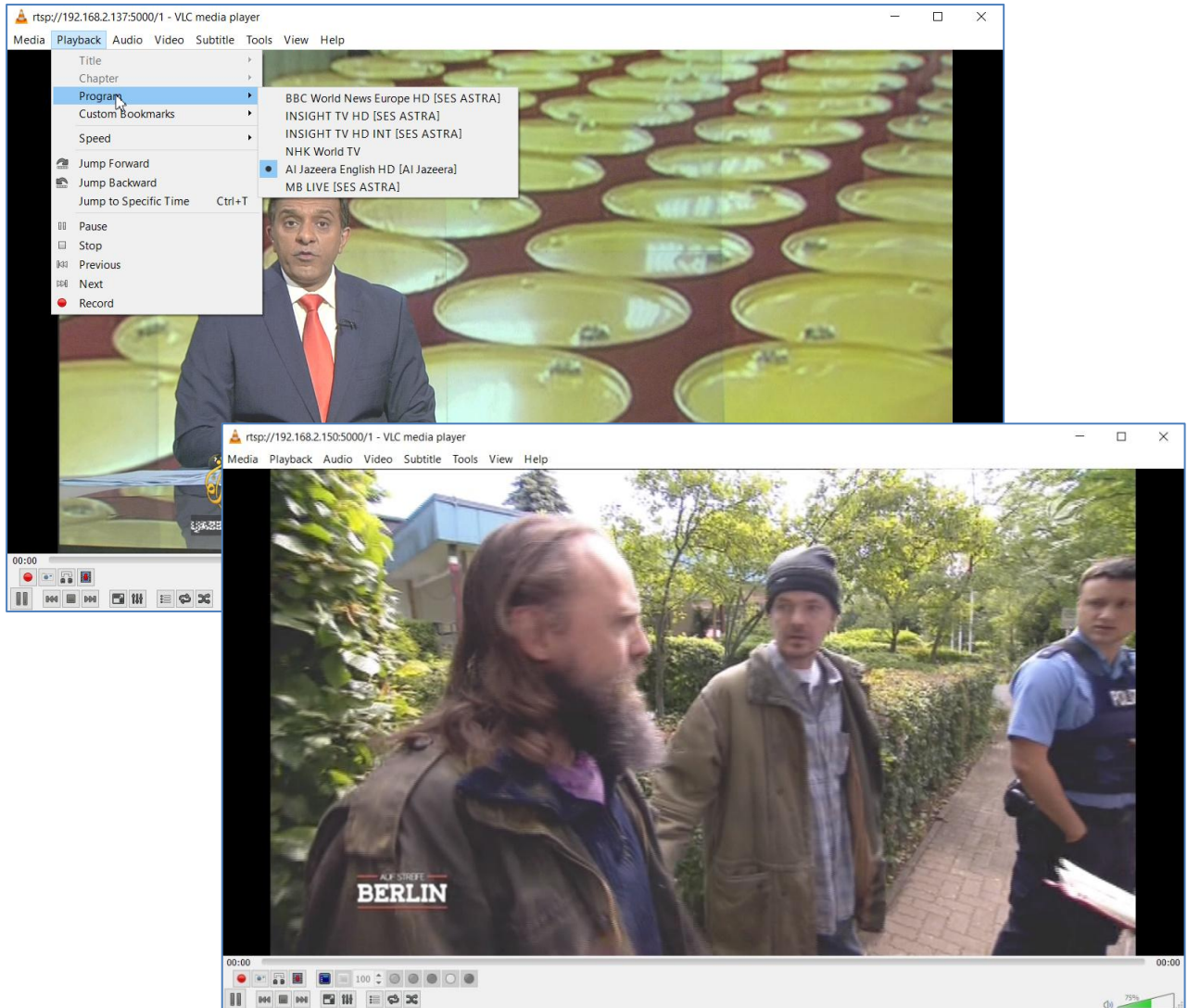

Software Updates:

IRENIS GmbH does not publish Soft- and Firmware-upgrades online. If you face some problems, please send us a bug-report along with all necessary data of the device(s). Nevertheless, here how it works for this unit:

The update files are 3. Almost packed as rar-files, so first you'll need to unzip them. Windows inbuilt zip function might not work, but you can try the freeware 7zip which works with rar-files:

1. enter the WEB GUI-->Firmware-Menu, update, maybe a good idea to save your config locally first:

The screenshot shows the 'Save Configuration' section of the web interface. On the left is a navigation menu with sections: Summary (Status), Parameters (Tuner Input, ASI Input, TS Config, Biss, SPTS select), and System (Network, Password, Save | Restore, Backup | Load, Firmware). The 'Save | Restore' option is selected. The main content area has three sections: 'SAVE CONFIGURATION' with a warning box and a 'Save config' button; 'RESTORE CONFIGURATION' with a warning box and a 'Restore' button; and 'FACTORY SET' with a warning box and a 'Factory set' button.

+ safe to file:

The screenshot shows the 'Backup Configuration' section of the web interface. The navigation menu is similar to the previous screenshot, but 'Backup | Load' is selected. The main content area has two sections: 'BACKUP CONFIGURATION' with a warning box and a 'Backup config' button; and 'LOAD CONFIGURATION' with a warning box containing two instructions, a file selection area with 'Datei auswählen' and 'Keine ausgewählt' buttons, and a 'Load config' button.

Then update IGS-900_Base_System_Firmware_encr_v01.01.02.07.pkg first:

FIRMWARE

Warning:

1. Update firmware(software and hardware) to get new function,please choose the right firmware to update.If you use a wrong file,the device may not work.
2. Update will keep a long time,please do not turn off the power, otherwise the device will not work.
3. After update,you must reboot device manually.

Work Mode:

Apply

Current Software Version: 1.03 Build 100 Jun 12 2017

Current Hardware Version: 1.10

Datei auswählen IGS-900_B...2.07.pkg

Update

Name

- IGS-900_16xTuner_IP_cpu_SPTS_v1.21_MPTS_v2.22_20180726.bin
- IGS-900_16xTuner_IP_fpga_SPTSv1.50_MPTSv2.30_20171031.fpga
- IGS-900_Base_System_Firmware_encr_v01.01.02.07.pkg**

Update System Now?

OK Abbrechen

Work Mode:

Apply

Current Software Version: 1.03 Build 100 Jun 12 2017

Current Hardware Version: 1.10

Datei auswählen IGS-900_B...2.07.pkg

Status: erase flash...

Update

Status: update success,please manual reboot the device.

BLANKOM®

FIRMWARE

Summary

- ▶ Status

Parameters

- ▶ Tuner Input
- ▶ ASI Input
- ▶ Biss
- ▶ Program Parse
- ▶ IP Stream

System

- ▶ Network
- ▶ Date | Time
- ▶ Password
- ▶ Save | Restore
- ▶ Backup | Load
- ▶ Firmware**

Warning:

1. Update firmware(software and hardware) to get new function,please choose the right firmware to update.If you use a wrong file,the device may not work.
2. Update will keep a long time,please do not turn off the power, otherwise the device will not work.
3. After update,you must reboot device manually.

Work Mode:

Status: switch success,please manual reboot the device.

Apply

Current Software Version: 2.55 Build 200 Oct 29 2021

Current Hardware Version: 2.b0

Durchsuchen... IGS_900_16xTuner_IP_cpu_SPTS_v1.58_MPTS_v2.56_20220223.bin

Status: update success,please manual reboot the device.



Update

2. Power off and on.
3. Default IP is 192.168.0.136, enter WEB GUI

System	
Software Version:	01.01.02.07
Hardware Version:	check cpu failed.please update CPU program.
Web Version:	1.00
System Version:	check web failed.please update CPU program
Product ID:	0 Day(s)-00:01:55
Uptime:	1.00 Build 100 Feb 21 2017



-->Firmware - Menu,

update IGS-900_16xTuner_IP_cpu_SPTS_v1.21_MPTS_v2.22_20180726.bin

 IGS-900_16xTuner_IP_cpu_SPTS_v1.21_MPTS_v2.22_20180726.bin
 IGS-900_16xTuner_IP_fpga_SPTSv1.50_MPTSv2.30_20171031.fpga
 IGS-900_Base_System_Firmware_encr_v01.01.02.07.pkg

Software Version:	01.01.02.07
Hardware Version:	check fpga failed.please update FPGA program
Web Version:	1.00
System Version:	
Product ID:	0 Day(s)-00:00:21
Uptime:	1.00 Build 100 Feb 21 2017

and IGS-900_16xTuner_IP_fpga_SPTSv1.50_MPTSv2.30_20171031.fpga.

 IGS-900_16xTuner_IP_cpu_SPTS_v1.21_MPTS_v2.22_20180726.bin	Update FPGA Now? <input type="button" value="OK"/>
 IGS-900_16xTuner_IP_fpga_SPTSv1.50_MPTSv2.30_20171031.fpga	
 IGS-900_Base_System_Firmware_encr_v01.01.02.07.pkg	

Status: update success,please manual reboot the device.

4. Power off and on again. Finished:

DEVICE INFORMATION															
<ul style="list-style-type: none"> ▶ Status Parameters <ul style="list-style-type: none"> ▶ Tuner Input ▶ ASI Input ▶ TS Config ▶ Biss ▶ SPTS select System ▶ Network 	<table border="1"> <thead> <tr> <th colspan="2">System</th> </tr> </thead> <tbody> <tr> <td>Software Version:</td> <td>1.21 Build 100 Jul 26 2018</td> </tr> <tr> <td>Hardware Version:</td> <td>1.50</td> </tr> <tr> <td>Web Version:</td> <td>1.00</td> </tr> <tr> <td>System Version:</td> <td>01.01.02.07(EN)</td> </tr> <tr> <td>Product ID:</td> <td>03508216-20000012-00000000-00000000</td> </tr> <tr> <td>Uptime:</td> <td>0 Day(s)-00:00:40</td> </tr> </tbody> </table>	System		Software Version:	1.21 Build 100 Jul 26 2018	Hardware Version:	1.50	Web Version:	1.00	System Version:	01.01.02.07(EN)	Product ID:	03508216-20000012-00000000-00000000	Uptime:	0 Day(s)-00:00:40
System															
Software Version:	1.21 Build 100 Jul 26 2018														
Hardware Version:	1.50														
Web Version:	1.00														
System Version:	01.01.02.07(EN)														
Product ID:	03508216-20000012-00000000-00000000														
Uptime:	0 Day(s)-00:00:40														

Don't be confused, 'Hardware-Version' shows actual FPGA –Software version.

5. Default IP is still 192.168.0.136.

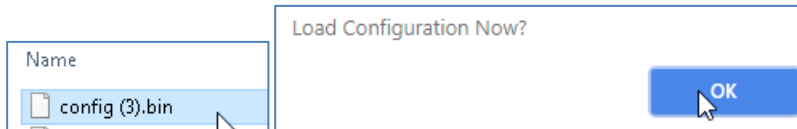
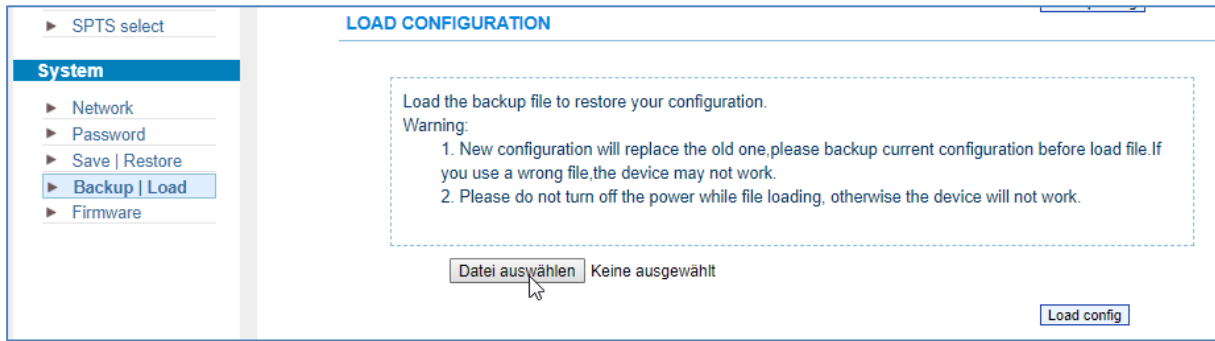

Remark: If you accidentally lost NMS IP address, you can RESET the device to its factory defaults by pressing the RESET-Button @ the front panel > 15 seconds or use the LCD-Menu:



Press the Lock-Button for a second, then the menu is accessible.

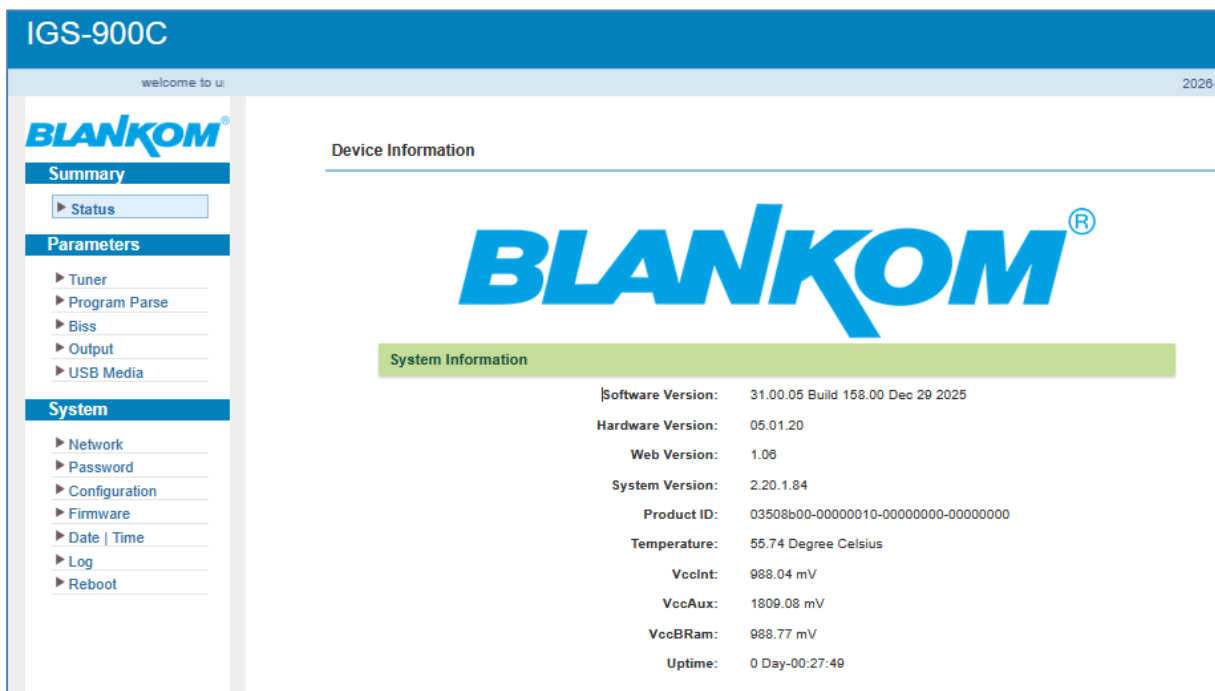

The CATV Tuners have a different menu than the DVB-SAT versions:

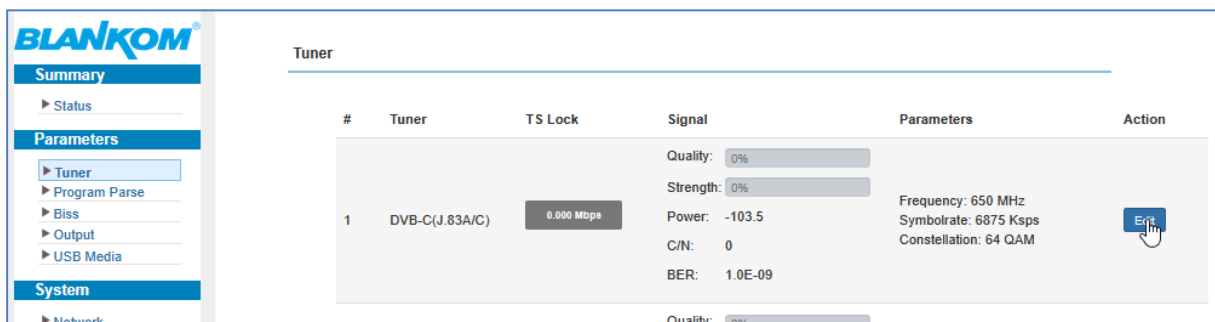

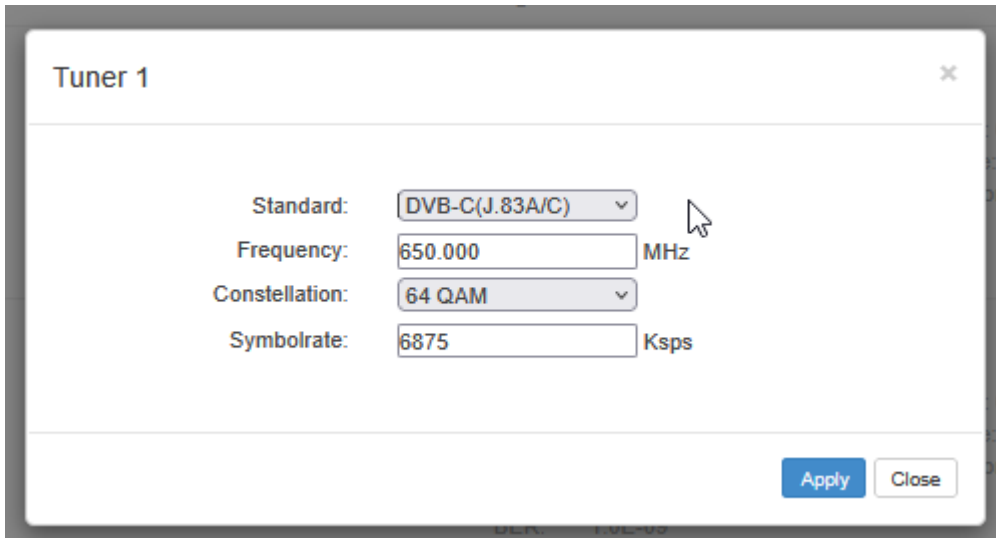

You need to know the DVB/ISDB-ATSC values of the to be received Frequency and Carrier/Modes:

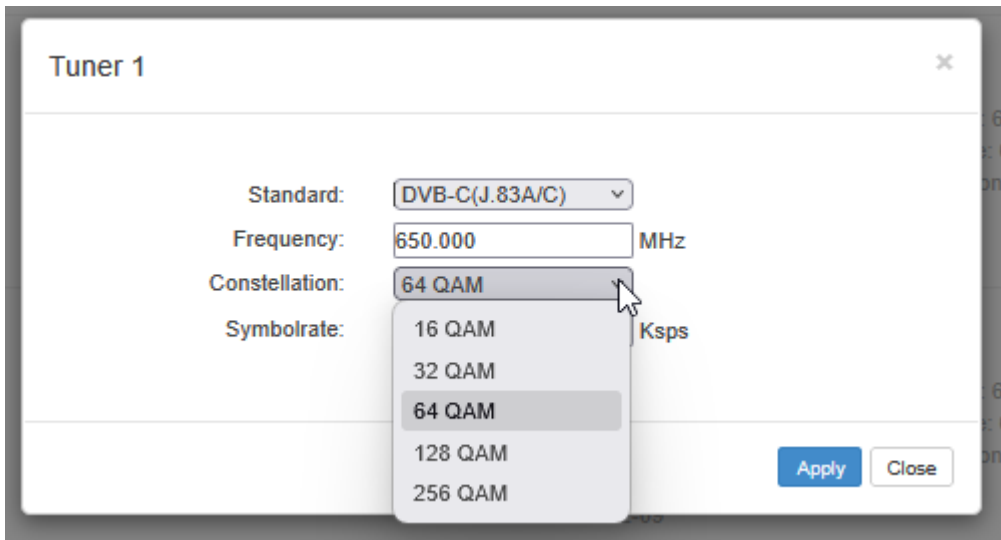

and:

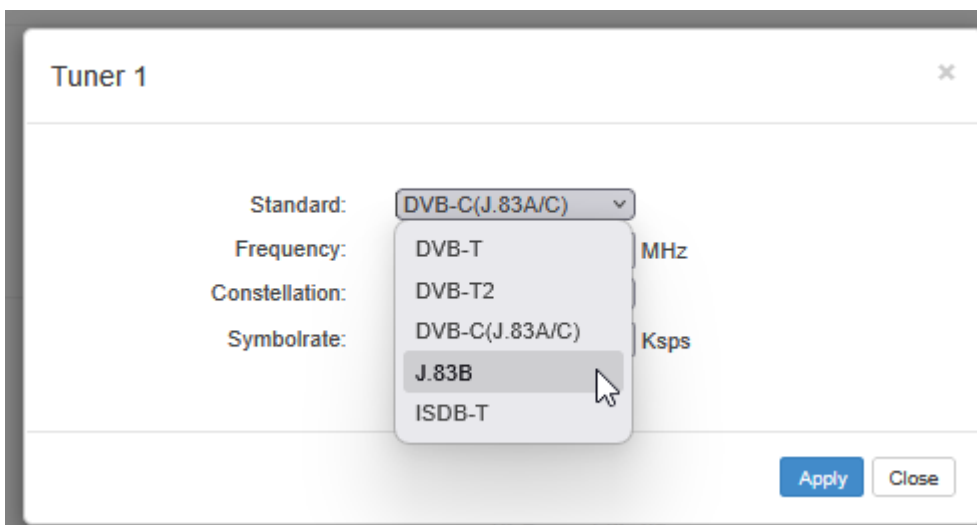

J.83B is equal to DVB-C Annex-B used in US related CATV networks in US and some countries like Korea...

Usual you have to set it to DVB-C (J.83A/C) to receive the Rest of The World CATV DVB-C signals.

The following Web-Menus are nearly similar to the older version except some differences but not so difficult to understand...

ANNEX MPEG

MPEG PSI/SI Information's:

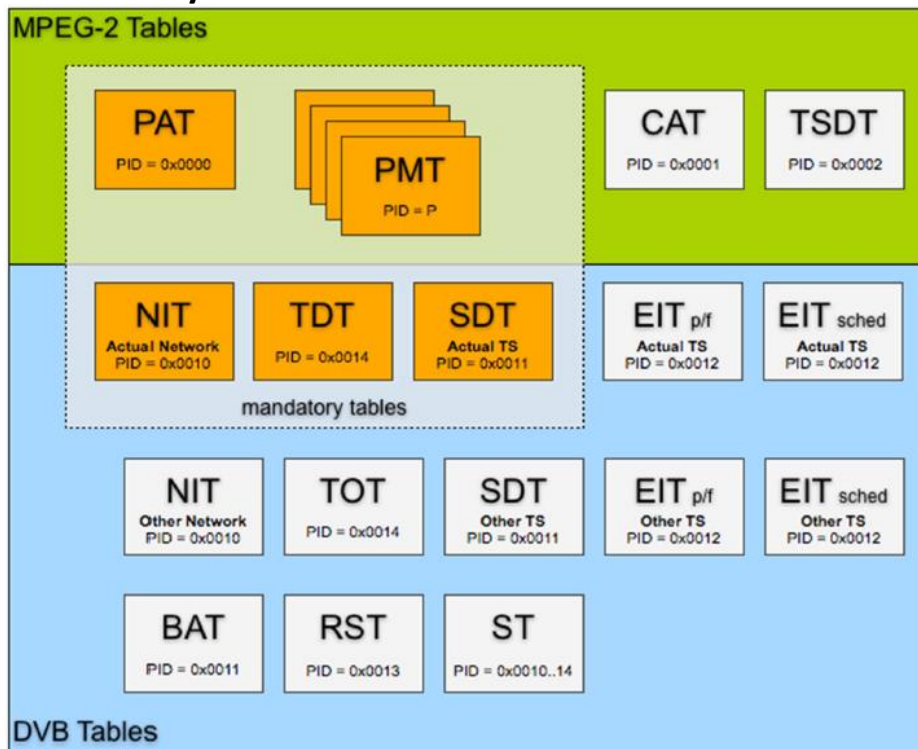

We assume, that the user is familiar with all abbreviations mentioned in this manual.

Table 1: PID allocation for SI

Table	PID value
PAT	0x0000
CAT	0x0001
TSDD	0x0002
reserved	0x0003 to 0x000F
NIT, ST	0x0010
SDT, BAT, ST	0x0011
EIT, ST, CIT (ETSI TS 102 323 [13])	0x0012
RST, ST	0x0013
TDT, TOT, ST	0x0014
network synchronization	0x0015
RNT (ETSI TS 102 323 [13])	0x0016
reserved for future use	0x0017 to 0x001B
link-local inband signalling	0x001C
measurement	0x001D
DIT	0x001E
SIT	0x001F

Recommendations:

As a **Multicast capable Switch**, we recommend is the HP (ARUVA) 2530 24G or 48G.

(For Floor switches we have an own branded one and support IGMP as well) IGMP should be set to ON in the port configs. The latest HP Firmware might not be the best choice. Better to test IGMP functions before installation into a HOT running System and eventually do a downgrade of the Firmware. This one work:

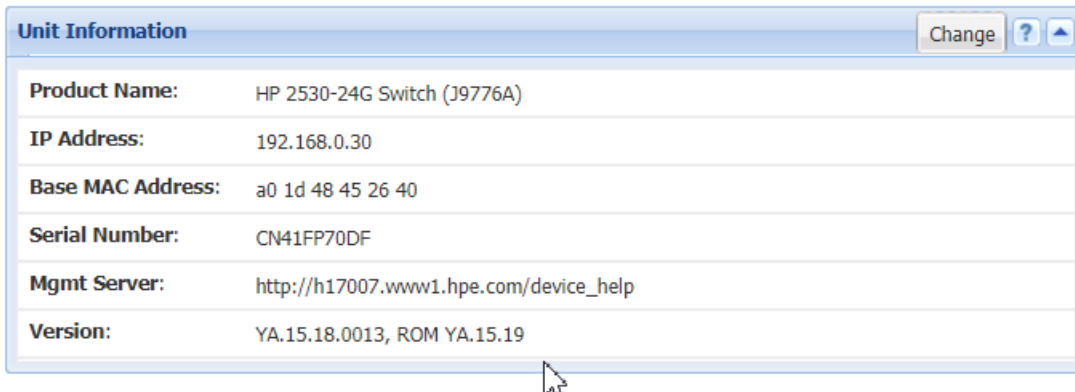

General notes about Streams:

Multicast streams:

Multicast Address Ranges:

We recommend, that the addressing of your Multicast streams should be in conjunction with this listings to avoid conflicts with other network equipment or protocols.

<https://www.iana.org/assignments/multicast-addresses/multicast-addresses.xhtml>

One small part from this:

IPv4 Multicast Address Space Registry

Last Updated

2018-01-05

Expert(s)

Stig Venaas

Note

Host Extensions for IP Multicasting [[RFC1112](#)] specifies the extensions required of a host implementation of the Internet Protocol (IP) to support multicasting. The multicast addresses are in the range 224.0.0.0 through 239.255.255.255. Address assignments are listed below.

The range of addresses between 224.0.0.0 and 224.0.0.255, inclusive, is reserved for the use of routing protocols and other low-level topology discovery or maintenance protocols, such as gateway discovery and group membership reporting. Multicast routers should not forward any multicast datagram with destination addresses in this range, regardless of its TTL.

Registries included below

- [Local Network Control Block \(224.0.0.0 - 224.0.0.255 \(224.0.0/24\)\)](#)
- [Internetwork Control Block \(224.0.1.0 - 224.0.1.255 \(224.0.1/24\)\)](#)
- [AD-HOC Block I \(224.0.2.0 - 224.0.255.255\)](#)
- [RESERVED \(224.1.0.0-224.1.255.255 \(224.1/16\)\)](#)
- [SDP/SAP Block \(224.2.0.0-224.2.255.255 \(224.2/16\)\)](#)
- [AD-HOC Block II \(224.3.0.0-224.4.255.255 \(224.3/16, 224.4/16\)\)](#)
- [RESERVED \(224.5.0.0-224.251.255.255 \(251 /16s\)\)](#)
- [DIS Transient Groups 224.252.0.0-224.255.255.255 \(224.252/14\)\)](#)
- [RESERVED \(225.0.0.0-231.255.255.255 \(7 /8s\)\)](#)
- [Source-Specific Multicast Block \(232.0.0.0-232.255.255.255 \(232/8\)\)](#)
- [GLOP Block](#)
- [AD-HOC Block III \(233.252.0.0-233.255.255.255 \(233.252/14\)\)](#)
- [Unicast-Prefix-based IPv4 Multicast Addresses](#)
- [Scoped Multicast Ranges](#)
- [Relative Addresses used with Scoped Multicast Addresses](#)

Multicast (as opposed to unicast) is used to send UDP packets from 1 source to multiple destination servers. This is useful for example for streaming from a satellite/DVB-T receiver to multiple receiving PCs for playback. Multicast can also be used on the output of an encoder to feed multiple streaming servers. Multicast only works with UDP and is not possible with TCP due to the 2 way nature of TCP, most commonly multicast is used with RTP and MPEG2-TS.

A multicast IP address must be chosen according to IANA information, we recommend using an address in the range **239.0.0.0 to 239.255.255.255** as this is reserved for private use. Using multicast addresses in the 224.0.0.0 range may clash with existing services and cause your stream to fail. For more details see <http://www.iana.org/assignments/multicast-addresses/multicast-addresses.xml>

Choosing a UDP port number for multicast streams is also important. Even if you use a different multicast IP for each of your streams, we strongly recommend using different UDP port numbers as well. This is because a server and all software running on the server receives ALL multicast traffic on an open port and extra processing is required to filter out the required traffic. If the each stream arrives on a different port, the server can safely ignore any traffic on ports that are not open. Port numbers MUST be chosen so that don't clash with any existing services or ephemeral ranges. The ephemeral range for Windows Vista, 7, 2008 is 49152 to 65535, for older Windows it is 1025 to 5000 and for Linux it is 32768 to 61000. For more information on Windows see <http://support.microsoft.com/kb/929851> Care should also be taken to avoid system ports 0 to 1024. See <http://www.iana.org/assignments/service-names-port-numbers/service-names-port-numbers.xml> Generally one of the unassigned You Ports (**1024-49151**) should be used, you can run the *netstat -abn* (as admin under windows) command to see which ports are currently in use.

Registered port

A **registered port** is a [network port](#) (a sub-address defined within the [Internet Protocol](#), in the range 1024–49151) assigned by the [Internet Assigned Numbers Authority](#) (IANA) (or by [Internet Corporation for Assigned Names and Numbers](#) (ICANN) before March 21, 2001,^[1] or by USC/ISI before 1998) for use with a certain protocol or application.

Ports with numbers 0–1023 are called *system or well-known ports*; ports with numbers 1024–49151 are called *you or registered ports*, and ports with numbers 49152–65535 are called *dynamic and/or private ports*.^[2] Both system and you ports are used by transport protocols (TCP, UDP, DCCP, SCTP) to indicate an application or service.

- **Ports 0–1023** – system or [well-known ports](#)
- **Ports 1024–49151** – you or registered ports
- **Ports >49151** – dynamic / private ports

https://en.wikipedia.org/wiki/List_of_TCP_and_UDP_port_numbers

Range for Ephemeral port

The [Internet Assigned Numbers Authority](#) (IANA) suggests the range 49152 to 65535 ($2^{15}+2^{14}$ to $2^{16}-1$) for dynamic or private ports.^[1]

Many [Linux kernels](#) use the port range 32768 to 61000.^[note 2] [FreeBSD](#) has used the IANA port range since release 4.6. Previous versions, including the [Berkeley Software Distribution](#) (BSD), use ports 1024 to 5000 as ephemeral ports.^{[2][3]}

[Microsoft Windows](#) operating systems through XP use the range 1025–5000 as ephemeral ports by default.^[4] [Windows Vista](#), [Windows 7](#), and [Server 2008](#) use the IANA range by default.^[5] [Windows Server 2003](#) uses the range 1025–5000 by default, until Microsoft security update MS08-037 from 2008 is installed, after which it uses the IANA range by default.^[6] Windows Server 2008 with Exchange Server 2007 installed has a default port range of 1025–60000.^[7] In addition to the default range, all versions of Windows since Windows 2000 have the option of specifying a custom range anywhere within 1025–65535.^{[8][9]}

Packet structure

		UDP Header																															
Offsets	Octet	0								1								2								3							
Octet	Bit	0	1	2	3	4	5	6	7	8	9	10	11	12	13	14	15	16	17	18	19	20	21	22	23	24	25	26	27	28	29	30	31
0	0	Source port																Destination port															
4	32	Length																Checksum															

The UDP header consists of 4 fields, each of which is 2 bytes (16 bits).^[1] The use of the fields "Checksum" and

"Source port" is optional in IPv4 (pink background in table). In IPv6 only the source port is optional (see below).

Source port number

This field identifies the sender's port when meaningful and should be assumed to be the port to reply to if needed. If not used, then it should be zero. If the source host is the client, the port number is likely to be an ephemeral port number. If the source host is the server, the port number is likely to be a well-known port number.^[4]

Destination port number

This field identifies the receiver's port and is required. Similar to source port number, if the client is the destination host then the port number will likely be an ephemeral port number and if the destination host is the server then the port number will likely be a well-known port number.^[4]

Length

A field that specifies the length in bytes of the UDP header and UDP data. The minimum length is 8 bytes because that is the length of the header. The field size sets a theoretical limit of 65,535 bytes (8 byte header + 65,527 bytes of data) for a UDP datagram. However the actual limit for the data length, which is imposed by the underlying [IPv4](#) protocol, is 65,507 bytes (65,535 – 8 byte UDP header – 20 byte [IP header](#)).^[4]

In IPv6 [jumbograms](#) it is possible to have UDP packets of size greater than 65,535 bytes.^[5] [RFC 2675](#) specifies that the length field is set to zero if the length of the UDP header plus UDP data is greater than 65,535.

Checksum

The [checksum](#) field may be used for error-checking of the header and data. This field is optional in IPv4, and mandatory in IPv6.^[6] The field carries all-zeros if unused.^[7]

RTP:

a part from: <https://tools.ietf.org/html/rfc3550>

Chapter 11:

RTP relies on the underlying protocol(s) to provide demultiplexing of RTP data and RTCP control streams. For UDP and similar protocols,

RTP SHOULD use an even destination port number and the corresponding RTCP stream SHOULD use the next higher (odd) destination port number.

For applications that take a single port number as a parameter and derive the RTP and RTCP port pair from that number, if an odd number is supplied then the application SHOULD replace that number with the **next lower (even)** number to use as the base of the port pair. For applications in which the RTP and RTCP destination port numbers are specified via explicit, separate parameters (using a signaling protocol or other means), the application MAY disregard the restrictions that the port numbers be even/odd and consecutive although the use of an even/odd port pair is still encouraged. The RTP and RTCP port numbers MUST NOT be the same since RTP relies on the port numbers to demultiplex the RTP data and RTCP control streams.

In a unicast session, both participants need to identify a port pair for receiving RTP and RTCP packets. Both participants MAY use the same port pair. A participant MUST NOT assume that the source port of the incoming RTP or RTCP packet can be used as the destination port for outgoing RTP or RTCP packets. When RTP data packets are being sent in both directions, each participant's RTCP SR packets MUST be sent to the port that the other participant has specified for reception of RTCP. The RTCP SR packets combine sender information for the outgoing data plus reception report information for the incoming data. If a side is not actively sending data (see [Section 6.4](#)), an RTCP RR packet is sent instead.

RTP (Real-Time Transport Protocol)	
Familie:	Netzwerkprotokoll
Einsatzgebiet:	Transport von Medien-Streams
Port:	beliebiger freier, gerader Port größer 1024
RTP im TCP/IP-Protokollstapel:	
Anwendung	RTP
Transport	UDP
Internet	IP (IPv4, IPv6)
Netzzugang	Ethernet Token Bus Token Ring FDDI ...
Standard:	RFC 3550 (RTP: A Transport Protocol for Real-Time Applications, 2003)

any port (even, not odd > 1024)

Note: Regarding SAP (Session Announcement Protocol)

IPv4 global scope sessions use multicast addresses in the range 224.2.128.0 - 224.2.255.255 with SAP Announcements being sent to 224.2.127.254 Port 9875 (note that 224.2.127.255 is used by the obsolete SAPv0 and MUST NOT be used).

IPv4 administrative scope sessions using administratively scoped IP multicast. The multicast address to be used for SAP announcements is the highest multicast address in the relevant administrative scope zone.

For example, if the scope range is 239.16.32.0 - 239.16.33.255, then 239.16.33.255 is used for SAP Announcements.

We assume, that this professional unit is used by professional technicians knowing all relevant norms, regulations, abbreviations (i.e. DVB, ATSC ...) and specifications.

Installation guide for F-connectors:

/ Installationshinweis für den F-Anschluß:

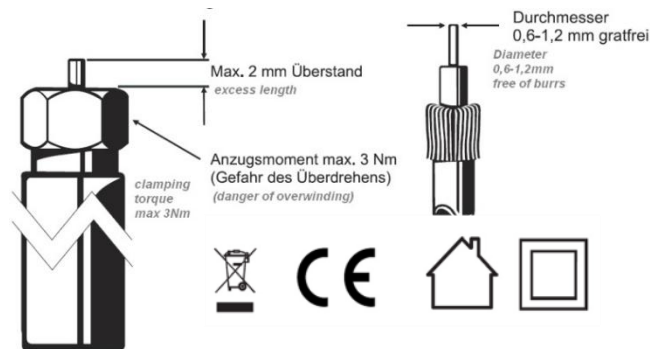

The LNC –connectors are almost marked as:

Die LNB-Anschlüsse sind meist entsprechend gekennzeichnet

HH= Horizontal High-Band

HL = Horizontal Low-Band = LH

VL = Vertical Low-Band = LV

VH= Vertical High-Band = HV

Electronic equipment is not household waste - in accordance with directive 2002/96/EC OF THE EUROPEAN PARLIAMENT AND THE COUNCIL dated 27th January 2003 on used electrical and electronic equipment, it must be disposed of properly.

At the end of its service life, take this unit for disposal to an appropriate official collection point

Elektronische Geräte gehören nicht in den Hausmüll, sondern müssen - gemäß Richtlinie 2002/96/EG DES EUROPÄISCHEN PARLAMENTS UND DES RATES vom 27. Januar 2003 über Elektro- und Elektronik-Altgeräte fachgerecht entsorgt werden.

Bitte geben Sie dieses Gerät am Ende seiner Verwendung zur Entsorgung an den dafür vorgesehenen öffentlichen Sammelstellen ab.

Appendix A



Product Disposal

Warning! Ultimate disposal of this product should be handled according to all national laws and regulations.

製品の廃棄

この製品を廃棄処分する場合、国の関係する全ての法律・条例に従い処理する必要があります。

警告

本产品的废弃处理应根据所有国家的法律和规章进行。

警告

本產品的廢棄處理應根據所有國家的法律和規章進行。

Warnung

Die Entsorgung dieses Produkts sollte gemäß allen Bestimmungen und Gesetzen des Landes erfolgen.

¡Advertencia!

Al deshacerse por completo de este producto debe seguir todas las leyes y reglamentos nacionales.

Attention

La mise au rebut ou le recyclage de ce produit sont généralement soumis à des lois et/ou directives de

סלולר וקווי

התקנה!

סלולר וקווי של סרטון זה נמצא להימנע מלעשות שימוש במוצר המיועד למינימום

respect de l'environnement. Renseignez-vous auprès de l'organisme compétent.

عند التخلص النهائي من هذا المنتج يتعين التعامل معه وفقاً لجميع القوانين واللوائح الوطنية

경고!

이 제품은 해당 국가의 관련 법규 및 규정에 따라 폐기되어야 합니다.

Waarschuwing

De uiteindelijke verwijdering van dit product dient te geschieden in overeenstemming met alle nationale wetten en reglementen.

Installation and safety instructions / Montage und

Sicherheitshinweise

- Die beschriebenen Geräte dienen ausschließlich der Installation von Satelliten-Empfangsanlagen.
- *The equipment described is designed solely for the installation of satellite receiver systems.*
- Jegliche anderweitige Nutzung oder die Nichtbeachtung dieses Anwendungshinweises hat den Verlust der Gewährleistung bzw. Garantie zur Folge.
- *Any other use, or failure to comply with these instructions, will result in voiding of warranty cover.*
- Die Geräte dürfen nur in trockenen Innenräumen montiert werden. Nicht auf oder an leichtentzündlichen Materialien montieren.
- *The equipment may only be installed in dry indoor areas. Do not mount on or against highly combustible materials.*
- Die Geräte sind mit einer Potenzial-Ausgleichsleitung (Cu, mindestens 4 mm²) zu versehen.
- *The equipment must be provided with an earthing wire (Cu, at least 4 mm²).*
- Die Sicherheitsbestimmungen der jeweils aktuellen Normen EN 60728-11 und EN 60065 sind zu beachten.
- *The safety regulations set out in the current EN 60728-11 and EN 60065 standards must be complied with*
- Verbindungsstecker: HF-Stecker 75 Ohm (Serie F) nach EN 61169-24
- *Connector: HF plug 75 Ohm (series F) to EN 61169-24.*
- **Nicht benutzte Teilnehmerausgänge** sollten mit 75-Ohm Widerständen (z. B. EMK 03) abgeschlossen werden. (Verringerung der terrestrischen Signalwelligkeit)
- **Unused subscriber ports** should be closed off by 75 Ohm resistors (e.g. EMK 03).
- **Nicht benutzte Kaskadenausgänge** sind mit 75 Ohm Widerständen inkl. DC-Blocker abzuschließen. 75 Ohm Widerstände ohne Gleichspannungssperren können das Gerät beschädigen!
- **Unused trunk outputs** must be terminated with 75Ohm resistors including DC Blocker. Otherwise the device may be inoperable or damaged.
- Bitte überprüfen Sie die Anlage vor Inbetriebnahme auf evtl. Kurzschlüsse der Koaxial-Kabel. Es ist darauf zu achten, daß die Eingangspegel der SAT-Ebenen möglichst gleich hoch sind. Power-LEDs zeigen den Betrieb an. Falls die nicht leuchten, bitte die Stromzufuhr kontrollieren.
- *Please check the installation against shortage in coax cables and connectors before switching on. The input levels should be adjusted accordingly. Power-LED's showing operational mode. If this is not illuminated, please check the power source.*
- **Stromführendes Gerät**
- **Current-carrying unit**
- Nicht öffnen oder am Gerät manipulieren!
- *Do not open or tamper with the unit!*
- Bei Arbeiten an der Anlage immer die Netzstecker aus der Steckdose ziehen!
- *When working on the system always unplug the mains plug from the wall socket!*
- Auf ausreichenden Abstand achten! Nach allen Seiten mind. 5 cm!
- *Ensure adequate clearance! Min. 5 cm to all sides!*
- Nicht über Kopf montieren.
- *Do not install overhead.*

- Für die Gerätekühlung muß freie Luftzirkulation möglich sein. Überhitzungsgefahr!
- *Free circulation of air must be possible to discharge the heat emitted by the unit. Risk of overheating!*
- Zulässige Umgebungstemperatur -20 bis +50°C
- *Permissible ambient temperature -20 to +50°C*

Important notes: / Zur Beachtung

- Auf das Netzgerät dürfen keine mit Flüssigkeit gefüllten Gegenstände gestellt werden.
- *No liquid-filled items may be placed on top of the power supply unit.*
- Das Netzgerät darf nicht Tropf- oder Spritzwasser ausgesetzt sein.
- *The power supply unit must not be exposed to dripping or splashing water.*
- Der Netzstecker muss ohne Schwierigkeiten zugänglich und benutzbar sein.
- *The mains plug must be easily accessible and operable.*
- Das Gerät kann nur durch Ziehen des Netzsteckers vom Netz getrennt werden.
- *The only reliable method of disconnecting the unit from the mains is to unplug it.*
- Bei größerem Durchmesser des Kabel- Innenleiters als 1,2 mm bzw. Grat können die Gerätebuchsen zerstört werden.
- *If the inner cable conductor diameter is greater than 1.2 mm or in case of burr, the device sockets may be destroyed.*

Bitte installieren Sie die Anschlüsse gemäß dem Aufdruck auf den Geräten – falls vorhanden

Please install according to the sticker on the devices if shown.

Hinweis: Elektrische Installationen sollten nur durch geschultes Fachpersonal vorgenommen werden!

Note: Electrical installations should only be done by well-educated and skilled technicians!

Umrechnungstabelle dB μ V <-> dBm / Conversions of Power @ 75 Ω

dBmV	dB μ V	dBm 75 Ω	mV _{RMS}	mW 75 Ω
8	68	-40.75	2.51	8.4E-05
9	69	-39.75	2.82	1.1E-04
10	70	-38.75	3.16	1.3E-04
11	71	-37.75	3.55	1.7E-04
12	72	-36.75	3.98	2.1E-04
13	73	-35.75	4.47	2.7E-04
14	74	-34.75	5.01	3.3E-04
15	75	-33.75	5.62	4.2E-04
16	76	-32.75	6.31	5.3E-04
17	77	-31.75	7.08	6.7E-04
18	78	-30.75	7.94	8.4E-04
19	79	-29.75	8.91	1.1E-03
20	80	-28.75	10.00	1.3E-03
21	81	-27.75	11.22	1.7E-03
22	82	-26.75	12.59	2.1E-03
23	83	-25.75	14.13	2.7E-03
24	84	-24.75	15.85	3.3E-03
25	85	-23.75	17.78	4.2E-03
26	86	-22.75	19.95	5.3E-03
27	87	-21.75	22.39	6.7E-03
28	88	-20.75	25.12	8.4E-03
29	89	-19.75	28.18	0.011
30	90	-18.75	31.62	0.013
31	91	-17.75	35.48	0.017
32	92	-16.75	39.81	0.021
33	93	-15.75	44.67	0.027
34	94	-14.75	50.12	0.033
35	95	-13.75	56.23	0.042
36	96	-12.75	63.10	0.053
37	97	-11.75	70.79	0.067
38	98	-10.75	79.43	0.084

dBmV	dBμV	dBm 75Ω	mV_{RMS}	mW 75Ω
39	99	-9.75	89.13	0.106
40	100	-8.75	100.00	0.133
41	101	-7.75	112.20	0.168
42	102	-6.75	125.89	0.211
43	103	-5.75	141.25	0.266
44	104	-4.75	158.49	0.335
45	105	-3.75	177.83	0.422
46	106	-2.75	199.53	0.531
47	107	-1.75	223.87	0.668
48	108	-0.75	251.19	0.841
49	109	0.25	281.84	1.059
50	110	1.25	316.23	1.333
51	111	2.25	354.81	1.679
52	112	3.25	398.11	2.113
53	113	4.25	446.68	2.660
54	114	5.25	501.19	3.349
55	115	6.25	562.34	4.216
56	116	7.25	630.96	5.308
57	117	8.25	707.95	6.683
58	118	9.25	794.33	8.413
59	119	10.25	891.25	10.591
60	120	11.25	1000.00	13.333
61	121	12.25	1122.02	16.786
62	122	13.25	1258.93	21.132
63	123	14.25	1412.54	26.604
64	124	15.25	1584.89	33.492
65	125	16.25	1778.28	42.164
66	126	17.25	1995.26	53.081
67	127	18.25	2238.72	66.825
68	128	19.25	2511.89	84.128

Sicherheitshinweise



Sicherheitshinweise bitte vor Montage bzw. Inbetriebnahme des Gerätes sorgfältig lesen und befolgen.

1. Installation

Gefahr: Das Gerät darf ausschließlich von sachverständigen Personen (siehe EN 60065), installiert und in Betrieb genommen werden.

Gefahr: Das Gerät und/oder die Verteilperipherie muss vor Inbetriebnahme gemäß EN 60728-11 vorschriftsmäßig geerdet sein

(Potentialausgleich) und bleiben, auch wenn das Gerät ausgebaut wird.

Gefahr: Das Gerät darf nicht auf brennbarem Untergrund montiert werden (Brandgefahr).

Gefahr: Schließen Sie das Gerät nur an eine vorschriftsmäßig installierte Steckdose mit Schutzleiter an.

Gefahr: Planen Sie den Montage- bzw. Aufstellungsort so, dass Kinder nicht am Gerät und dessen Anschlüssen spielen können. Es droht Gefahr durch elektrischen Schlag (Lebensgefahr).

Gefahr: Wählen Sie einen Montage- bzw. Aufstellungsort, an dem unter keinen Umständen Flüssigkeiten oder Gegenstände in das Gerät gelangen können (z.B. Kondenswasser, Gießwasser etc.).

Gefahr: Lüftungsschlitze und Kühlkörper sind wichtige Funktionselemente an den Geräten. Bei Geräten, die Kühlkörper oder Lüftungsschlitze haben, muss daher unbedingt darauf geachtet werden, dass diese keinesfalls abgedeckt oder zugebaut werden. Sorgen Sie außerdem für eine großzügig bemessene Luftzirkulation um das Gerät. Damit verhindern Sie mögliche Schäden am Gerät sowie Brandgefahr durch Überhitzung. Gewährleisten Sie einen Mindestabstand von 20cm um das Gerät zu anderen Gegenständen.

Gefahr: Der Montage- bzw. Aufstellort muss eine sichere Verlegung aller angeschlossenen Kabel zulassen. Stromversorgungskabel sowie Zuführungskabel dürfen nicht durch irgendwelche Gegenstände beschädigt oder gequetscht werden. Es ist darüber hinaus unbedingt darauf zu achten, dass Kabel nicht in die direkte Nähe von Wärmequellen verlegt werden (z.B. Heizkörper, andere Elektrogeräte, Kamin etc.) (Brandgefahr), (Gefahr durch elektrischen Schlag).

Gefahr: Um sowohl Beschädigungen am Gerät als auch mögliche Folgeschäden (Brandgefahr) zu vermeiden, dürfen für Wandmontage vorgesehene Geräte nur auf einer ebenen Grundfläche montiert werden und nicht über Kopf.

Warnung: (Nur für optische Sender sowie deren Verteilperipherie) Blicken Sie auf keinen Fall direkt oder indirekt in den Laserstrahl. Schließen Sie das Gerät erst an die Stromversorgung an, wenn alle elektrischen und optischen Leitungen sicher verbunden sind.

Warnung: Die Sicherheitsbestimmungen der jeweils aktuellen Normen EN 60728-11 und EN 60065 sind zwingend einzuhalten.

Warnung: Befolgen Sie auch alle anwendbaren nationalen Sicherheitsvorschriften und Normen.

Warnung: Der Netzstecker des Gerätes muß jederzeit leicht erreichbar sein.

Warnung: Befolgen Sie alle Instruktionen in den gerätespezifischen Bedienungsanleitungen

2. Betrieb

Gefahr: Das Gerät darf nur in trockenen Räumen bei nicht tropischem Klima betrieben werden. In feuchten Räumen oder im Freien besteht die Gefahr von Kurzschluß (Brandgefahr) oder elektrischen Schlag (Lebensgefahr).

Gefahr: Stecken Sie keine Gegenstände durch die Lüftungsschlitze. Gefahr durch elektrischen Schlag (Lebensgefahr).

Gefahr: Stellen Sie keine mit Flüssigkeit gefüllten Gefäße (wie z. B. Vasen) auf das Gerät. Es droht Gefahr durch elektrischen Schlag (Lebensgefahr) oder (Brandgefahr).

Gefahr: Es dürfen keine offenen Brandquellen, wie z. B. brennende Kerzen, auf das Gerät gestellt werden (Brandgefahr).

Gefahr: Sorgen Sie für einen Freiraum von mindestens 20cm um das Gerät. Die Belüftung des Gerätes darf nicht durch Abdecken der Belüftungsöffnungen mit Gegenständen wie z. B. Zeitungen, Tischdecken, Gardinen usw. behindert werden (Brandgefahr).

Warnung: Befolgen Sie alle Instruktionen in der gerätespezifischen Bedienungsanleitung.

3. Wartung

Gefahr: Wartungsarbeiten sind stets von sachverständigen Personen (siehe EN 60065) vorzunehmen.

Gefahr: Keine Servicearbeiten bei Gewitter. Es droht Gefahr eines elektrischen Schlags (Lebensgefahr).

Warnung (nur für Geräte mit Batterie): Explosionsgefahr bei unsachgemäßem Auswechseln der Batterie. Ersatz nur durch den gleichen Typ!

Warnung: Batterien dürfen nicht übermäßiger Wärme wie Sonnenschein, Feuer oder dergleichen ausgesetzt werden (Explosionsgefahr).

Warnung: Verwenden Sie nur das Zubehör des Herstellers oder Zubehör mit identischen technischen Eigenschaften.

Warnung: (Bei optischen Sendern sowie deren Verteilperipherie) ziehen Sie den Netzstecker bevor das Gerät ausgebaut wird.

4. Reparatur

Gefahr: Das Gerät darf nur durch sachverständige Personen (siehe EN 60065) geöffnet werden. Vor Öffnen des Gerätes Netzstecker ziehen

bzw. Stromzuführung entfernen, andernfalls besteht Lebensgefahr! Das Gerät darf nur mit montierter Netzteilabdeckung an Spannung angeschlossen und betrieben werden. Dies gilt auch, wenn Sie das Gerät reinigen oder an den Anschlüssen arbeiten.

Gefahr: Reparaturen am Gerät sind ausschließlich vom Fachmann (siehe EN 60065) unter Beachtung der geltenden VDE-Richtlinien durchzuführen.

Gefahr: Verwenden Sie nur Bauteile des gleichen Typs und mit identischen technischen Eigenschaften für die Reparatur, andernfalls droht Gefahr eines elektrischen Schlags (Lebensgefahr) und Brandgefahr.

Warnung (Bei optischen Sendern sowie deren Verteilperipherie): ziehen Sie den Netzstecker bevor das Gerät ausgebaut wird.

Bei Fragen zur Reparatur wenden Sie sich an den IRENIS-Service:

E-Mail: info@blankom.de , Kontakt: www.blankom.de

5. Verkauf

Vorsicht: Im Falle eines Verkaufs müssen diese Sicherheitshinweise und die Bedienungsanleitung des entsprechenden Geräts dem Käufer ausgehändigt werden.

6. Entsorgung

Vorsicht: Entsorgen Sie das Gerät entsprechend den geltenden umweltrechtlichen Bestimmungen. Elektrische und elektronische Geräte dürfen nicht in den Hausmüll!

Vorsicht: Entsorgen Sie Batterien (falls vorhanden), entsprechend den geltenden umweltrechtlichen Bestimmungen.

Contact:

IRENIS GmbH

Hauptstr. 29

31171 Nordstemmen- Germany

Phone: +49 5069 4809781

Managing Director: Dipl.Ing. Murad ÖnoI

Commercial Register: HRB 206370 / District Court Hildesheim



Web: www.blankom.de E-Mail: contact@blankom.de

Document History:

Initial: July 2017	First release	RRI
November 2018 V1.1	Added Network hints	RRI
sept 2019 v1.2	Addons and corrections	Ralf Riedel
Aug. 2020	New Front-design	RRI
Aug.2021	Added note for DVB-C Tuner	RR
May 2022	Added DVB-C addons	RR
May 2026	Added IGS-900C	RR

CE Declaration

EU Declaration of Conformity

1. **Product model:** BLANKOM IGS 900

2. **Name and address of the manufacturer or his authorised representative:**

IRENIS GmbH
Hauptstr. 29
31171 Nordstemmen/Germany
+49 (0) 5069 4809 783
info@blankom.de

3. **This declaration of conformity is issued under the sole responsibility of the manufacturer.**

4. **Object of the declaration:**

Equipment: DVB/IP GATEWAY, IRD
Brand name: BLANKOM
Model/type: IGS-900

5. **The object of the declaration described above is in conformity with the relevant Union harmonization legislation:**

Low Voltage Directive (LVD) 2006/95/EC,
Electromagnetic Compatibility Directive (EMC) 2014/30/EU,

6. **References to the relevant harmonised standards used or references to the other technical specifications in relation to which conformity is declared:**

LVD: EN 60950-1:2006+A11:2009+A1:2010+A12:2011+A2:2013

EMC: EN 55022: 2010+AC:2011
EN 61000-3-2:2014, EN 61000-3-3:2013
EN 55024: 2010
EN 61000-4-2: 2009, EN 61000-4-3: 2006+A1:2008+A2:2010
EN 61000-4-4: 2012, EN 61000-4-5: 2014
EN 61000-4-6: 2014, EN 61000-4-8: 2010, EN 61000-4-11: 2004

7. **Signed for and on behalf of:**

At Nordstemmen, 11th of September, 2019

Authorised representative:
IRENIS GmbH

IRENIS GmbH
Hauptstr. 29
31171 Nordstemmen

Dipl.-Ing. Murad Onol, Managing Director

DVB-C Channel plan

Anyway, we should adjust the QAM Channels according to the ITU Cenelec Channel line ups, so that TV sets can easier tune by using the default channel lists:

Example starting with

Superband^{LUJ}

Analog Kanal	Analog-frequenz in MHz (7 MHz-Raster)	Digital Kanal	Digital-frequenz in MHz (8 MHz-Raster)	Analog Kanal	Analog-frequenz in MHz (7 MHz-Raster)	Digital Kanal	Digital-frequenz in MHz (8 MHz-Raster)
S01	105,25			S11	231,25	(D234)	(234±4)
S02	112,25	D114	114±4	S12	238,25		
S03	119,25	D122	122±4	S13	245,25	(D242)	(242±4)
S04	126,25	D130	130±4	S14	252,25	(D250)	(250±4)
S05	133,25			S15	259,25	(D258)	(258±4)
S06	140,25	D138	138±4	S16	266,25	(D266)	(266±4)
S07	147,25	D146	146±4	S17	273,25	(D274)	(274±4)
S08	154,25	D154	154±4	S18	280,25	(D282)	(282±4)
S09	161,25	D162	162±4	S19	287,25	(D290)	(290±4)
S10	168,25	D170	170±4	S20	294,25	(D298)	(298±4)

That's enough for 16 channels.

Next page full plan....

Technical Appendix Telekom/CENELEC Channel Plan

The output levels for broadband amplifiers have been determined in conformity with the following channel allocations:

			Telekom ¹⁾ channel plan 36 Channels	CENELEC- Plan ²⁾ 19/29/42 Channels
TV Bands	Channel PAL	(MHz)		
	I	2 48,25	•	•
		3 55,25		
Midband		4 62,25	•	
		Pilot 80,15	(•)	
		S 2 112,25		
		S 3 119,25		•
		S 4 126,25		
		S 5 133,25	•	
		S 6 140,25	•	
		S 7 147,25	•	
		S 8 154,25	•	
		S 9 161,25	•	
III		S10 168,25		
		5 175,25	•	•
		6 182,25		
		7 189,25	•	
				•
		8 196,25		
		9 203,25	•	
				•
		10 210,25		
		11 217,25	•	
				•
		12 224,25		
Superband		S 11 231,25	•	•
		S 12 238,25	•	
		S 13 245,25	•	
				•
		S 14 252,25	•	
		S 15 259,25	•	
				•
		S 16 266,25	•	
		S 17 273,25	•	
		S 18 280,25	•	
Extended Superband		S 19 287,25	(•)	•
		S 20 294,25	•	
		S 21 303,25	•	
		S 22 311,25	•	•
		S 23 319,25	•	
		S 24 327,25	•	•
		S 25 335,25	•	
		S 26 343,25		•
		S 27 351,25	•	
		S 28 359,25	•	•
		S 29 367,25	•	
		S 30 375,25	•	•
		S 31 383,25	•	•
		S 32 391,25	•	•
		S 33 399,25		
		S 34 407,25	•	•
		S 35 415,25	•	
		S 36 423,25	•	•
		S 37 431,25	•	

			Telekom ¹⁾ channel plan 36 Channels	CENELEC- Plan ²⁾ 19/29/42 Channels
Extended Superband	S 38	439,25	•	•
	S 39	447,25		•
	S 40	455,25		
	S 41	463,25		•
IV	21	471,25	•	
	22	479,25	•	•
	23	487,25	•	
	24	495,25	•	•
	25	503,25	•	
	26	511,25	•	•
	27	519,25	•	
	28	527,25	•	•
	29	535,25	•	
	30	543,25	•	•
	31	551,25	•	
	32	559,25	•	
	33	567,25	•	•
	34	575,25	•	
	35	583,25	•	•
	36	591,25	•	
	V	37	599,25	•
38		607,25		
39		615,25		
40		623,25		
41		631,25		
42		639,25		
43		647,25		
44		655,25		
45		663,25		•
46		671,25		
47		679,25		•
48		687,25		
49		695,25		•
50	703,25			
51	711,25		•	
52	719,25			
53	727,25		•	
54	735,25			
55	743,25		•	
56	751,25			
57	759,25		•	
58	767,25			
59	775,25		•	
60	783,25			
61	791,25		•	
62	799,25			
63	807,25		•	
64	815,25			
65	823,25		•	
66	831,25			
67	839,25		•	
68	847,25			
69	855,25		•	

¹⁾ accord. to FTZ 156 TR 4, Telekom channel plan 7/8 MHz (450 MHz).
54 channels up to 606 MHz.

²⁾ accord. to DIN EN 50083-3, 19 channels up to 450 MHz, 29 channels up to 606 MHz, 42 channels up to 862 MHz.

Technical data IGS-924 / IGS-900 overview

Input		16/24 tuner inputs + 2x ASI in, TS rec/Player ->SPTS output, Rf-Loops			
Tuner Section	<i>Option: Multi-mode tuners</i>	DVB-C	Frequency In	60...890MHz	
			Standard	J.83A/C (DVB-C), J.83B = US norm*,	
			Constellation	16/32/64*/128/256 QAM	
		DVB-T/T2	Frequency In	60...890MHz	
			Bandwidth	6*/7/8 M bandwidth	
		ISDB-T, ATSC	Frequency In	60...890MHz	
		Satellite	DVB-S	Frequency In	950...2150MHz
				Symbol rate	0.5...45Msps
				Signal Strength	-65... -25dBm
	FEC			1/2, 2/3, 3/4, 5/6, 7/8	
	Constellation			QPSK	
	Max input bitrate			≤ 125 Mbps	
	DVB-S2x		Frequency In	950...2150MHz	
			Symbol rate	QPSK/8PSK /16APSK :0.5...45 MSps 32APSK: 0.5...34MSps;	
			FEC	QPSK: 1/2, 3/5, 2/3, 3/4, 4/5, 5/6, 8/9, 9/10 8PSK: 3/5, 2/3, 3/4, 5/6, 8/9, 9/10 16APSK: 2/3, 3/4, 4/5, 5/6, 8/9, 9/10 32APSK: 3/4, 4/5, 5/6, 8/9, 9/10	
			Constellation	QPSK, 8PSK, 16APSK, 32APSK	
			Max input bitrate	≤ 125 Mbps	
			DVB-S2X	Frequency In	950...2150MHz
	Symbol rate			QPSK/8PSK /16APSK :0.5...45 MSps 8APSK: 0.5...40 MSps 32APSK: 0.5...34 MSps	
	FEC			QPSK: 1/2, 3/5, 2/3, 3/4, 4/5, 5/6, 8/9, 9/10, 13/45, 9/20, 11/20 8PSK: 3/5, 2/3, 3/4, 5/6, 8/9, 9/10 8APSK: 5/9-L, 26/45-L 16APSK: 2/3, 3/4, 4/5, 5/6, 8/9, 9/10, 1/2-L, 8/15-L, 5/9-L, 26/45, 3/5, 3/5-L, 28/45, 23/36, 2/3-L, 25/36, 13/18, 7/9, 77/90 32APSK: 3/4, 4/5, 5/6, 8/9, 9/10, 2/3-L, 32/45, 11/15, 7/9	
Constellation	QPSK, 8PSK, 8APSK, 16APSK, 32APSK				
Max input bitrate	≤125 Mbps				
BISS Descrambling	Mode 1, Mode E (Up to 850Mbps) (descrambling individual program's)				
Output	Unicast and Multicast 128 SPTS IP output over UDP and RTP/RTSP protocol				

	through GE1 & GE2 port (IP address and port number of GE1 and GE2 are independent)	
	2x ASI out (selectable SPTS)	
	TS-Recorder/Player-TS-file Streamer from connected USB-PEN/SSD	
System	Web-Server based management via 100BaseT port	
	software upgrade via Web-IF	
Miscellaneous	Dimension	482mm×230mm×44mm (W×L×H)
	Approx. weight	3.6kg
	Environment	0...45°C (working condition); -20...80°C (in Storage)
	Power requirements	100...240VAC, 50/60Hz
	Power consumption	20W