

IPTV HEVC/h.264 Encoder with 4/8/12 Inputs

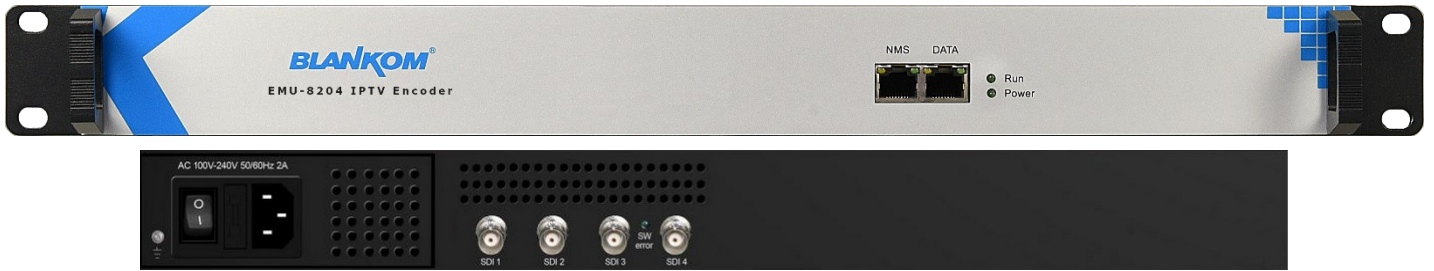

- 4 SDI input, 8 SPTS IPTV and 1 MPTS output (EMU 8204)
- 8 SDI input, 8 SPTS IPTV and 2 MPTS output (EMU 8208)
- 12 SDI input, 12 SPTS IPTV and 3 MPTS output (EMU 8212)
- On-Screen Graphics, Scrolling Text, QR Code insertion optional
- Accurate PCR adjusting
- PID filtering and re-mapping
- PSI/SI rebuilding and editing
- “Null PKT Filter” function
- Audio: MPEG1L2, AAC, AC3pass
- Remote control by a modern Web based management
- Updates via Web-interface

*4 ... 12 HD-SDI input
IPTV Encoder
with Text or Graphic
Logo-Insertion*

BLANKOM EMU 8200 series:

MPEG4* AVC/H.264 and HEVC/h.265 HD IP Encoder is a professional HD audio & video encoding and multiplexing device. Input: 4, 2x4 or 3x4 HD-SDI Video input interfaces, supporting HEVC and MPEG-4* Video encoding and MPEG 1L2, AAC and AC3 passing audio encodings. This very compact Encoder simultaneously encodes up to 4, 8 or 12 HD-SDI compatible HD Audio & Video channels to IP out as a multiplexed 1..3 MPTS and 4, 8 or 12 SPTS IP streams as UDP/RTP/RTSP Multi-/Unicast per Module. Every encoded Video-picture can be added with Text, Graphic or QR-code overlays: As optional feature available. High integrated and cost effective design fits perfect into widely use cases in varieties of digital distribution systems such as cable TV digital head-end, satellite digital TV broadcasting etc.

* Dep. On common Resolutions

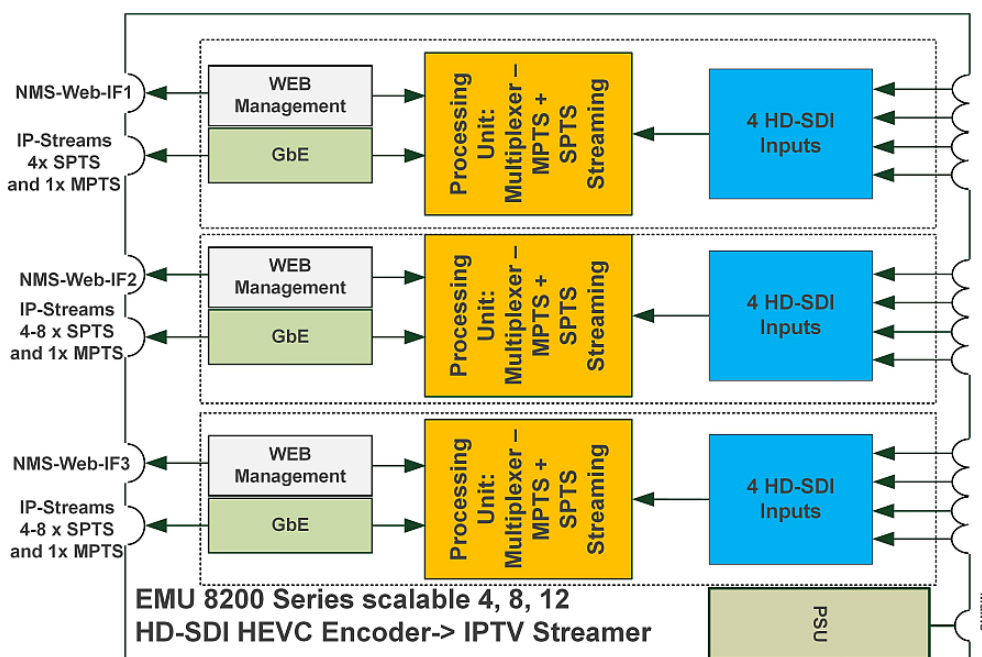

Technical specifications:

Input	4/8/12×HD-SDI inputs (4 each Module)			
Video Encoding	Encoding Format	HEVC/ H.265 , MPEG 4 AVC/H.264		
	Resolution (HD-SDI) Note: because of its modular Fujitsu chip it demands per module on each input the same signal resolutions	Input	Output	
			HEVC/H.265	MPEG-4 AVC/H.264
		4x1080P-50	4x1080P-50	2x1080P-50
		4x1080P-60	4x1080P-60	2x1080P-60
		4x1080I-50	4x1080P-50	4x1080I-50 2x1080P-50
		4x1080I-60	4x1080P-60	4x1080I-60 2x1080P-60
		4x720P-50	4x720P-50	4x720P-50
	4x720P-60	4x720P-60	4x720P-60	
	Chroma	4:2:0		
Bitrate	0.5Mbps...20Mbps (each channel)			
Encoding Rate Control	CBR/VBR			
GOP Structure	IBBP, IPPP			
Advanced picture correction	De-interlacing, Noise Reduction, Sharpening			
Audio Encoding	Encoding Format	MPEG-1 Layer 2, LC-AAC, HE-AAC, HE-AAC V2, AC3 Passthrough		
	Sampling rate	48KHz		
	Bit-rate (each channel)	48Kbps...384Kbps (MPEG-1 Layer 2 & LC-AAC) 24 Kbps...128 Kbps (HE-AAC) 18 Kbps...56 Kbps (HE-AAC V2)		
	Audio Gain	0...255		
OSD (optional)	Text/logo/QR code Insertion Function OnScreenDisplay Overlay			
Stream output per module	IP (1 MPTS and maximum 4 SPTS) output over UDP/RTP/RTSP per module, 1000M/100M Base-T Ethernet interface (unicast/ multicast); IPv4, IPv6 output IP null packet filter: MPTS- PID-8191dec adding or dropping			
System	Web based management			
	English control interface			
	Ethernet software upgrade			
Miscellaneous	Dimension (W× L× H)	482mm×328mm×44mm		
	Approximately weight	5kg		
	Temperature	0...45°C(work), -20...80°C (Storage)		
	Power	AC 100V-220V±10%, 50/60Hz		

EMU-8200 Series HEVC/H.265 encoder's advantages:

1. Providing correct adapted Transport-Streams for modulators

These HEVC/H.265 encoder adopts Fujitsu chips which offers a most stable bitrate with lower fluctuation compared with other encoding chips, so optimal as TS -source for modulators. It is widely used in variety of digital distribution systems such as CATV digital head-end, satellite and terrestrial digital TV, etc.

2. Encoding with highest compression format—B frame (IBBP)

What is B Frame?

There are 3 major picture types used in the different video algorithms, they are I, P and B.

They are different in the following characteristics:

I-frames are the least compressible but don't require other video frames to decode.

P-frames can use data from previous frames to decompress and are more compressible than I-frames.

B-frames can use both previous and forward frames for data reference to get the highest amount of data compression.

Frame Type	Byte of data/KB	Compression Ratio
I	18	7:1
P	6	20:1
B	2.5	50:1

In one word, B frame is the highest compression format which makes it possible to process HD video at low bit rates. A HEVC/H.265 encoder is not able to reduce bandwidth unless it is operating with B frames. In the encoder-codec parameters, B frame is often described in the GOP (Group of Pictures) structure, like "IBBP".

Corresponding products:

- IP to 16 QAM DVB-C Modulator HDC-5016
- HDC-5004 IP to QAM Modulator with remuxed TV services i.e. for hospitality content addons to existing networks
- Digital Signage: IP Decoder HDD-275
- IPTV Middleware Server OMNISCREENTV + SetTopBoxes or Hospitality TV Sets from tested vendors
- BLANKOM IPTV STB: 7500+ / 6700+